



Welcome to E-XFL.COM

Understanding [Embedded - Microcontroller, Microprocessor, FPGA Modules](#)

Embedded - Microcontroller, Microprocessor, and FPGA Modules are fundamental components in modern electronic systems, offering a wide range of functionalities and capabilities. Microcontrollers are compact integrated circuits designed to execute specific control tasks within an embedded system. They typically include a processor, memory, and input/output peripherals on a single chip. Microprocessors, on the other hand, are more powerful processing units used in complex computing tasks, often requiring external memory and peripherals. FPGAs (Field Programmable Gate Arrays) are highly flexible devices that can be configured by the user to perform specific logic functions, making them invaluable in applications requiring customization and adaptability.

Applications of [Embedded - Microcontroller,](#)

Details

Product Status	Obsolete
Module/Board Type	MPU Core
Core Processor	ARM926EJ-S, AM1808
Co-Processor	-
Speed	450MHz
Flash Size	8MB
RAM Size	128MB
Connector Type	-
Size / Dimension	1.18" x 1.57" (30mm x 40mm)
Operating Temperature	-40°C ~ 85°C
Purchase URL	https://www.e-xfl.com/product-detail/logic-pd/somam1808-10-1602qhir

PRODUCT BRIEF:

Logic PD :: Texas Instruments
www.logicpd.com/am1808-som-m1

AM1808 SOM-M1 System on Module

The AM1808 System on Module (SOM) is a compact, product-ready hardware and software solution that fast forwards embedded designs while reducing risk and controlling cost.

Based on the Texas Instruments (TI) AM1808 processor and designed in the SOM-M1 form factor, the AM1808 module offers essential features for handheld and embedded networking applications.

The AM1808 SOM-M1 brings the industry leading low power ARM926 core to a small, off-the-shelf solution. The standard SOM-M1 form factor allows developers to reuse existing baseboard designs when upgrading to new Sitara processors, which extends roadmap possibilities for end-products.

The compact size of the AM1808 SOM-M1 is ideal for medical patient monitoring wearables and other portable instrumentation applications; the built-in Serial ATA (SATA) controller provides fast access to large capacity storage devices. For medical, industrial, audio, and communication

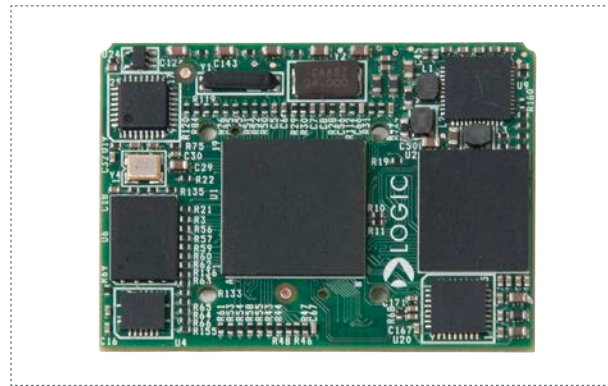

AM1808 SOM-M1

products, the AM1808 SOM-M1 allows for powerful versatility, long-life, and greener products.

Two Zoom™ Development Kit options allow developers to choose the platform best suited to their application needs. By starting with the corresponding Zoom Development Kit, engineers can write application software on the same hardware that will be used in their final product.

AM1808 SOM-M1 :: HIGHLIGHTS:

- +Product-ready System on Module with a TI AM1808 processor running at 450 MHz
- +Compact form factor—SOM-M1 (30 x 40 x 4.5 mm)
- +Long product lifecycle
- +Linux™ and Windows® Embedded CE SDKs
- +Commercial temp (0°C to 70°C)
Industrial temp (-40°C to 85°C)
- +RoHS compliant

ZOOM DEVELOPMENT KIT :: OPTIONS:

eXperimenter Kit

- +AM1808 SOM-M1
- +Application baseboard
- +4.3" WQVGA LCD panel
- +Necessary accessories to immediately get up and running

EVM Development Kit

- +AM1808 SOM-M1
- +Application baseboard
- +User Interface (UI) board
- +WLAN daughter card
- +4.3" WQVGA LCD panel
- +Necessary accessories to immediately get up and running

AM1808 SOM-M1 Block Diagram

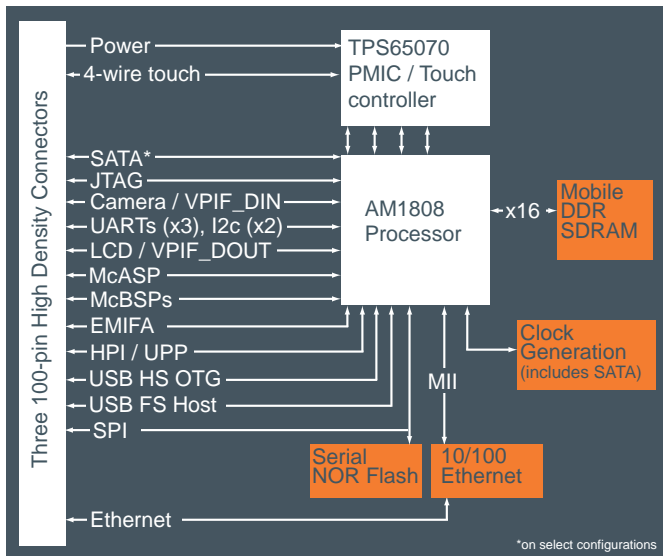

NOTE: Block diagram is for reference purposes only; it is not drawn to scale.

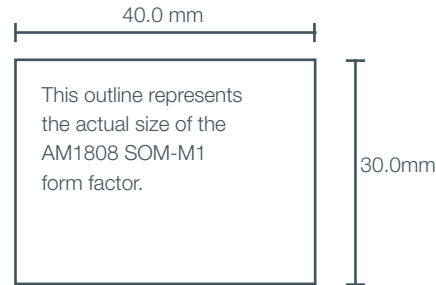

AM1808 SOM-M1 Ordering Information

Model Number	Processor	Speed (MHz)	mDDR (MB)	NOR Flash (MB)	Wired Ethernet	SATA	Temp (°C)
SOMAM1808-10-1502QHCR	AM1808	450	64	8	Y	N	0°–70°
SOMAM1808-10-1602QHCR	AM1808	450	128	8	Y	N	-40°–85°

NOTE: Custom configurations are available by special order. Please contact Logic PD Sales for details.

Zoom™ AM1808 Development Kit Ordering Information

Development Kit ¹	Model Number	SOM-M1 Configuration Included	Suggested Resale
EVM Development Kit	TMDXEVMWIFI1808L	SOMAM1808-10-1602AHCR ²	<input type="checkbox"/>
eXperimenter Kit	TMDSEXP1808L	SOMAM1808-10-1602AHCR ²	<input type="checkbox"/>

NOTES: 1. The EVM and eXperimenter Kits are available through Texas Instruments distributors.
2. This configuration has added power measurement circuitry.

Product Features

Processor

+TI AM1808 processor with ARM926EJ-S core running at 450 MHz

SDRAM Memory

+Mobile DDR (64 or 128 MB)

Flash Memory

+Scalable serial NOR flash (8 MB standard)

Display

+Programmable color LCD controller supports up to a 16 bpp TFT interface

Touchscreen

+Integrated 4-wire touchscreen controller (TPS65070)

Network Support

+10/100 Base-T Ethernet controller

Serial ATA Controller

+SATA 1.5 & 3.0 Gbps support

PC Card Expansion

+MMC/SD card support

USB

+One USB 2.0 high-speed On-the-Go interface
+One USB 1.1 full-speed host interface

Serial Ports

+Three external UARTs
+Two I2Cs

GPIO

+Programmable I/O depending on peripheral requirements

Software

+U-Boot (bootloader/monitor)
+Linux™ SDK
+Windows® Embedded CE SDK

Mechanical

+SOM-M1 form factor
+30.0 mm wide x 40.0 mm long x 4.5 mm high

RoHS Compliant



411 N. Washington Ave. Suite 400 Minneapolis, MN 55401
T : 612.672.9495 F : 612.672.9489 I : www.logicpd.com
© 2014 Logic PD, Inc. All rights reserved. PN: 1015625 Rev E

LOGIC PD WEBSITE :: DESIGN RESOURCES:

+Logic PD Products : www.logicpd.com/products
+Logic PD Technical Support : www.logicpd.com/support
+Logic PD Sales : www.logicpd.com/contact/inquiry

