

Welcome to E-XFL.COM

Understanding [Embedded - FPGAs \(Field Programmable Gate Array\)](#)

Embedded - FPGAs, or Field Programmable Gate Arrays, are advanced integrated circuits that offer unparalleled flexibility and performance for digital systems. Unlike traditional fixed-function logic devices, FPGAs can be programmed and reprogrammed to execute a wide array of logical operations, enabling customized functionality tailored to specific applications. This reprogrammability allows developers to iterate designs quickly and implement complex functions without the need for custom hardware.

Applications of Embedded - FPGAs

The versatility of Embedded - FPGAs makes them indispensable in numerous fields. In telecommunications,

Details

Product Status	Active
Number of LABs/CLBs	540
Number of Logic Elements/Cells	4320
Total RAM Bits	94208
Number of I/O	206
Number of Gates	-
Voltage - Supply	2.375V ~ 3.465V
Mounting Type	Surface Mount
Operating Temperature	-40°C ~ 100°C (TJ)
Package / Case	256-LFBGA
Supplier Device Package	256-CABGA (14x14)
Purchase URL	https://www.e-xfl.com/product-detail/lattice-semiconductor/lcmxo3lf-4300c-5bg256i

Features

■ Solutions

- Smallest footprint, lowest power, high data throughput bridging solutions for mobile applications
- Optimized footprint, logic density, IO count, IO performance devices for IO management and logic applications
- High IO/logic, lowest cost/IO, high IO devices for IO expansion applications

■ Flexible Architecture

- Logic Density ranging from 640 to 9.4K LUT4
- High IO to LUT ratio with up to 384 IO pins

■ Advanced Packaging

- 0.4 mm pitch: 1K to 4K densities in very small footprint WLCSP (2.5 mm x 2.5 mm to 3.8 mm x 3.8 mm) with 28 to 63 IOs
- 0.5 mm pitch: 640 to 6.9K LUT densities in 6 mm x 6 mm to 10 mm x 10 mm BGA packages with up to 281 IOs
- 0.8 mm pitch: 1K to 9.4K densities with up to 384 IOs in BGA packages

■ Pre-Engineered Source Synchronous I/O

- DDR registers in I/O cells
- Dedicated gearing logic
- 7:1 Gearing for Display I/Os
- Generic DDR, DDRx2, DDRx4

■ High Performance, Flexible I/O Buffer

- Programmable sysIO™ buffer supports wide range of interfaces:
 - LVCMOS 3.3/2.5/1.8/1.5/1.2
 - LVTTTL
 - LVDS, Bus-LVDS, MLVDS, LVPECL
 - MIPI D-PHY Emulated
 - Schmitt trigger inputs, up to 0.5 V hysteresis
- Ideal for IO bridging applications
- I/Os support hot socketing
- On-chip differential termination
- Programmable pull-up or pull-down mode

■ Flexible On-Chip Clocking

- Eight primary clocks
- Up to two edge clocks for high-speed I/O interfaces (top and bottom sides only)
- Up to two analog PLLs per device with fractional-n frequency synthesis
 - Wide input frequency range (7 MHz to 400 MHz)

■ Non-volatile, Multi-time Programmable

- Instant-on
 - Powers up in microseconds
- Optional dual boot with external SPI memory
- Single-chip, secure solution
- Programmable through JTAG, SPI or I²C
- MachXO3L includes multi-time programmable NVCM
- MachXO3LF infinitely reconfigurable Flash
 - Supports background programming of non-volatile memory

■ TransFR Reconfiguration

- In-field logic update while IO holds the system state

■ Enhanced System Level Support

- On-chip hardened functions: SPI, I²C, timer/counter
- On-chip oscillator with 5.5% accuracy
- Unique TraceID for system tracking
- Single power supply with extended operating range
- IEEE Standard 1149.1 boundary scan
- IEEE 1532 compliant in-system programming

■ Applications

- Consumer Electronics
- Compute and Storage
- Wireless Communications
- Industrial Control Systems
- Automotive System

■ Low Cost Migration Path

- Migration from the Flash based MachXO3LF to the NVCM based MachXO3L
- Pin compatible and equivalent timing

and oscillators dynamically. These features help manage static and dynamic power consumption resulting in low static power for all members of the family.

The MachXO3L/LF devices are available in two versions C and E with two speed grades: -5 and -6, with -6 being the fastest. C devices have an internal linear voltage regulator which supports external VCC supply voltages of 3.3 V or 2.5 V. E devices only accept 1.2 V as the external VCC supply voltage. With the exception of power supply voltage both C and E are functionally compatible with each other.

The MachXO3L/LF PLDs are available in a broad range of advanced halogen-free packages ranging from the space saving 2.5 x 2.5 mm WLCSP to the 19 x 19 mm caBGA. MachXO3L/LF devices support density migration within the same package. Table 1-1 shows the LUT densities, package and I/O options, along with other key parameters.

The MachXO3L/LF devices offer enhanced I/O features such as drive strength control, slew rate control, PCI compatibility, bus-keeper latches, pull-up resistors, pull-down resistors, open drain outputs and hot socketing. Pull-up, pull-down and bus-keeper features are controllable on a “per-pin” basis.

A user-programmable internal oscillator is included in MachXO3L/LF devices. The clock output from this oscillator may be divided by the timer/counter for use as clock input in functions such as LED control, key-board scanner and similar state machines.

The MachXO3L/LF devices also provide flexible, reliable and secure configuration from on-chip NVCM/Flash. These devices can also configure themselves from external SPI Flash or be configured by an external master through the JTAG test access port or through the I²C port. Additionally, MachXO3L/LF devices support dual-boot capability (using external Flash memory) and remote field upgrade (TransFR) capability.

Lattice provides a variety of design tools that allow complex designs to be efficiently implemented using the MachXO3L/LF family of devices. Popular logic synthesis tools provide synthesis library support for MachXO3L/LF. Lattice design tools use the synthesis tool output along with the user-specified preferences and constraints to place and route the design in the MachXO3L/LF device. These tools extract the timing from the routing and back-annotate it into the design for timing verification.

Lattice provides many pre-engineered IP (Intellectual Property) LatticeCORE™ modules, including a number of reference designs licensed free of charge, optimized for the MachXO3L/LF PLD family. By using these configurable soft core IP cores as standardized blocks, users are free to concentrate on the unique aspects of their design, increasing their productivity.

Figure 2-4. Slice Diagram

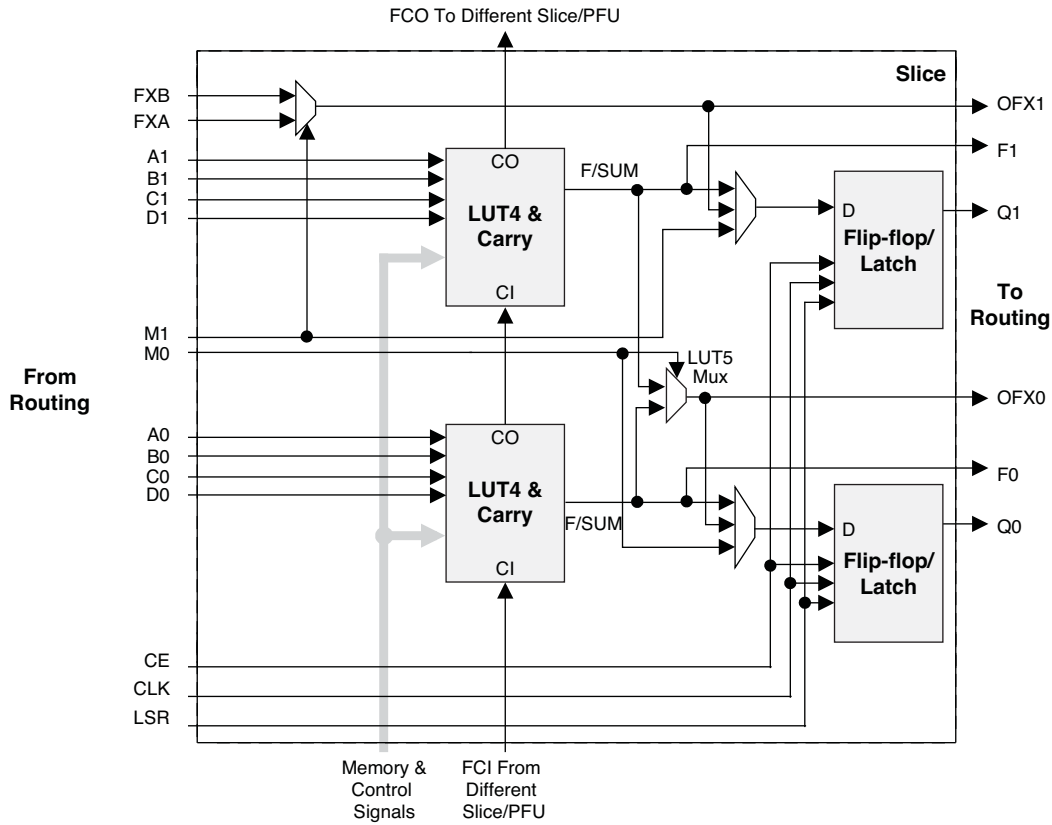

For Slices 0 and 1, memory control signals are generated from Slice 2 as follows:

- WCK is CLK
- WRE is from LSR
- DI[3:2] for Slice 1 and DI[1:0] for Slice 0 data from Slice 2
- WAD [A:D] is a 4-bit address from slice 2 LUT input

Table 2-2. Slice Signal Descriptions

Function	Type	Signal Names	Description
Input	Data signal	A0, B0, C0, D0	Inputs to LUT4
Input	Data signal	A1, B1, C1, D1	Inputs to LUT4
Input	Multi-purpose	M0/M1	Multi-purpose input
Input	Control signal	CE	Clock enable
Input	Control signal	LSR	Local set/reset
Input	Control signal	CLK	System clock
Input	Inter-PFU signal	FCIN	Fast carry in ¹
Output	Data signals	F0, F1	LUT4 output register bypass signals
Output	Data signals	Q0, Q1	Register outputs
Output	Data signals	OFX0	Output of a LUT5 MUX
Output	Data signals	OFX1	Output of a LUT6, LUT7, LUT8 ² MUX depending on the slice
Output	Inter-PFU signal	FCO	Fast carry out ¹

1. See Figure 2-3 for connection details.
2. Requires two PFUs.

Figure 2-6. Secondary High Fanout Nets for MachXO3L/LF Devices

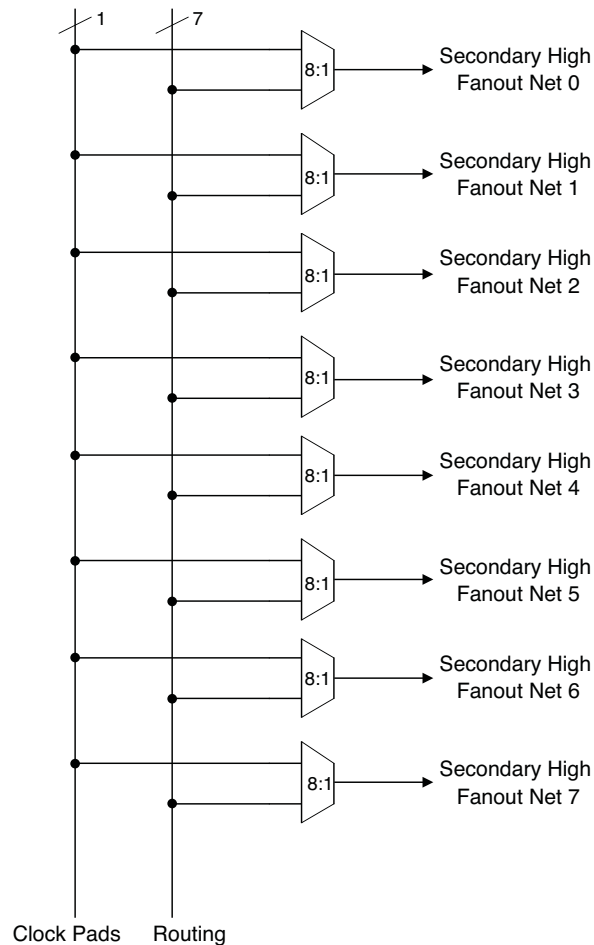

sysCLOCK Phase Locked Loops (PLLs)

The sysCLOCK PLLs provide the ability to synthesize clock frequencies. All MachXO3L/LF devices have one or more sysCLOCK PLL. CLKI is the reference frequency input to the PLL and its source can come from an external I/O pin or from internal routing. CLKFB is the feedback signal to the PLL which can come from internal routing or an external I/O pin. The feedback divider is used to multiply the reference frequency and thus synthesize a higher frequency clock output.

The MachXO3L/LF sysCLOCK PLLs support high resolution (16-bit) fractional-N synthesis. Fractional-N frequency synthesis allows the user to generate an output clock which is a non-integer multiple of the input frequency. For more information about using the PLL with Fractional-N synthesis, please see TN1282, [MachXO3 sysCLOCK PLL Design and Usage Guide](#).

Each output has its own output divider, thus allowing the PLL to generate different frequencies for each output. The output dividers can have a value from 1 to 128. The output dividers may also be cascaded together to generate low frequency clocks. The CLKOP, CLKOS, CLKOS2, and CLKOS3 outputs can all be used to drive the MachXO3L/LF clock distribution network directly or general purpose routing resources can be used.

The LOCK signal is asserted when the PLL determines it has achieved lock and de-asserted if a loss of lock is detected. A block diagram of the PLL is shown in Figure 2-7.

The setup and hold times of the device can be improved by programming a phase shift into the CLKOS, CLKOS2, and CLKOS3 output clocks which will advance or delay the output clock with reference to the CLKOP output clock.

Figure 2-11. Group of Four Programmable I/O Cells

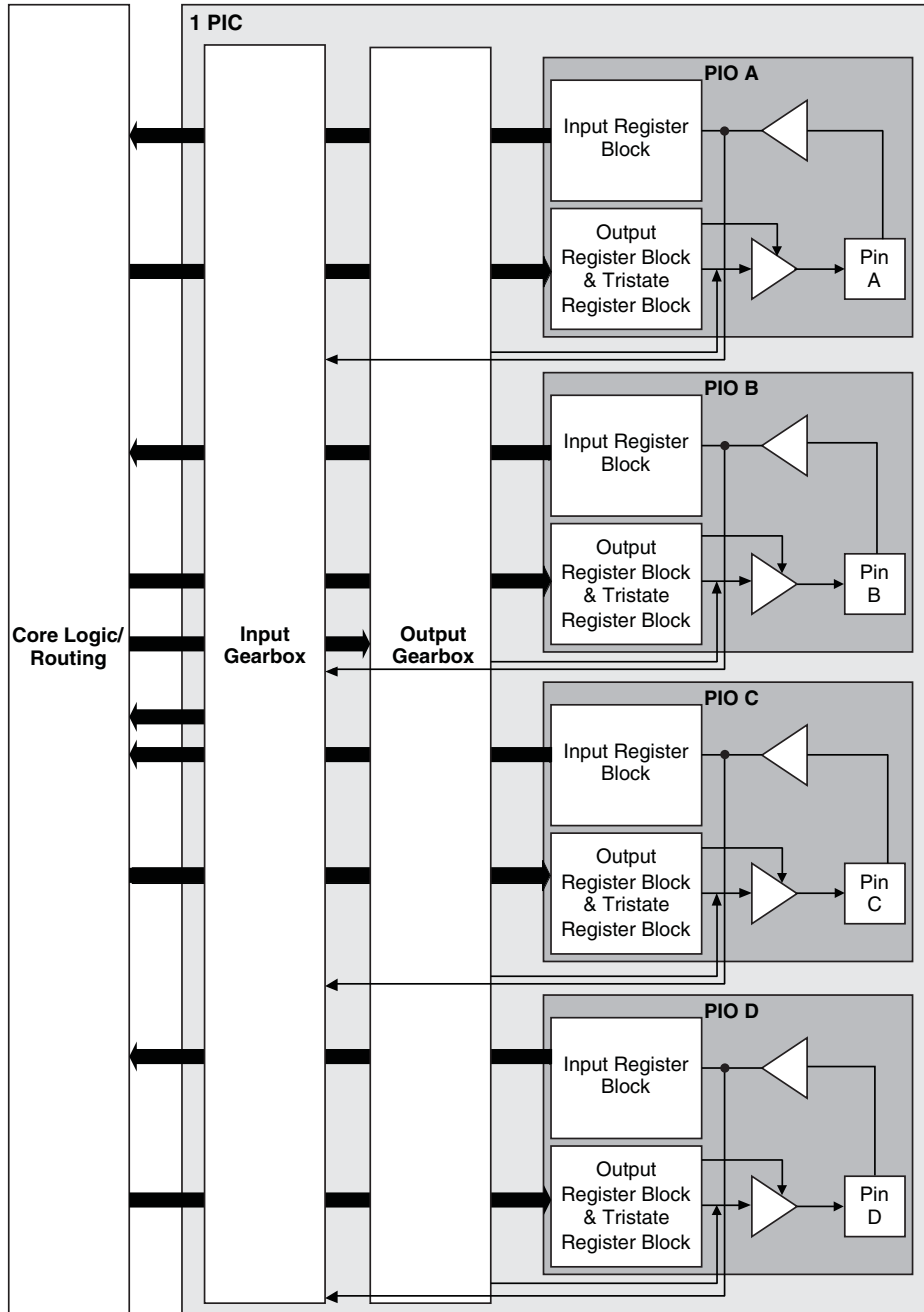
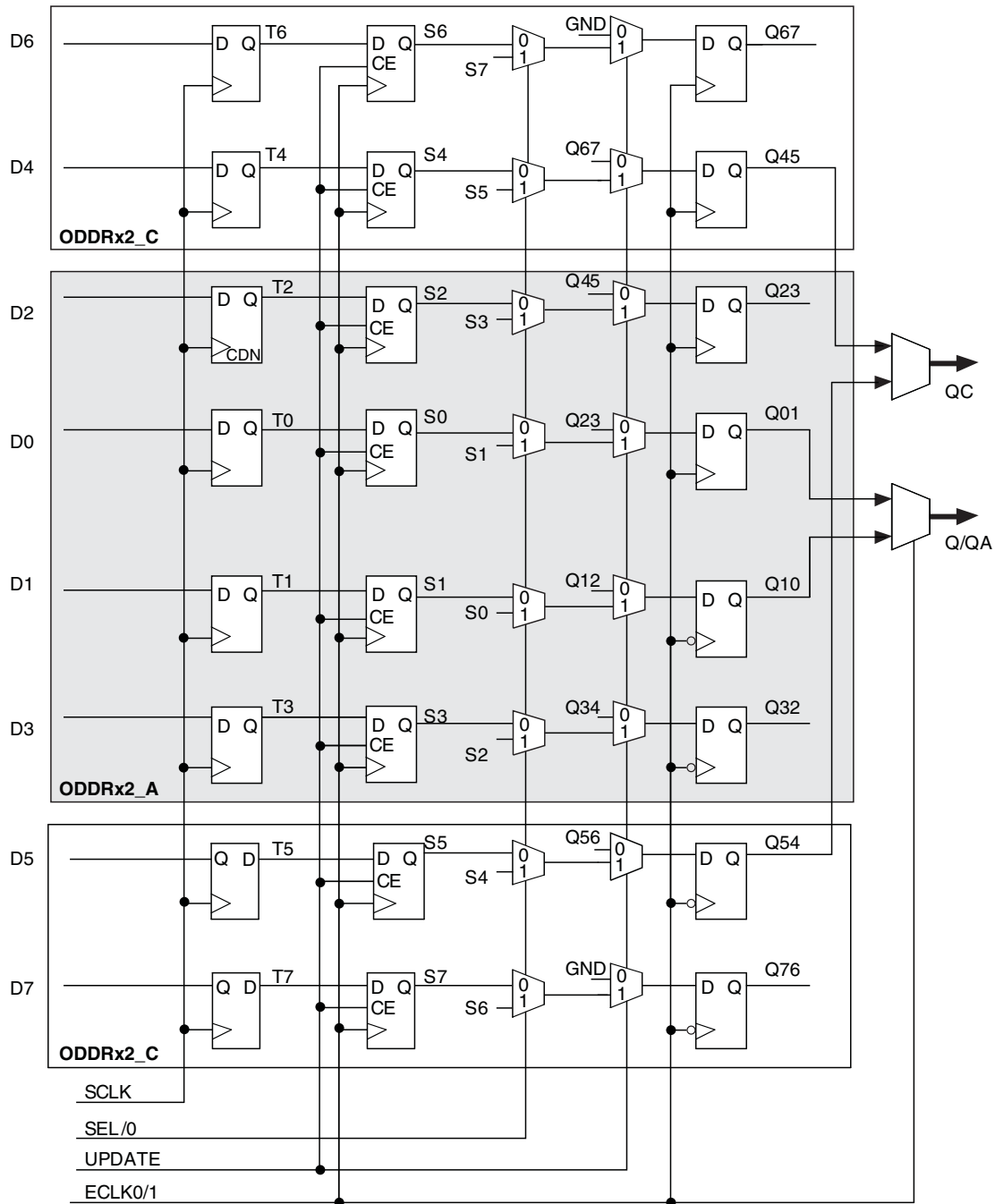

Figure 2-14. Output Gearbox



More information on the output gearbox is available in TN1281, [Implementing High-Speed Interfaces with MachXO3 Devices](#).

sysIO Buffer

Each I/O is associated with a flexible buffer referred to as a sysIO buffer. These buffers are arranged around the periphery of the device in groups referred to as banks. The sysIO buffers allow users to implement a wide variety of standards that are found in today's systems including LVCMOS, TTL, PCI, LVDS, BLVDS, MLVDS and LVPECL.

Each bank is capable of supporting multiple I/O standards. In the MachXO3L/LF devices, single-ended output buffers, ratioed input buffers (LVTTL, LVCMOS and PCI), differential (LVDS) input buffers are powered using I/O supply voltage (V_{CCIO}). Each sysIO bank has its own V_{CCIO} .

MachXO3L/LF devices contain three types of sysIO buffer pairs.

1. Left and Right sysIO Buffer Pairs

The sysIO buffer pairs in the left and right banks of the device consist of two single-ended output drivers and two single-ended input buffers (for ratioed inputs such as LVCMOS and LVTTL). The I/O pairs on the left and right of the devices also have differential input buffers.

2. Bottom sysIO Buffer Pairs

The sysIO buffer pairs in the bottom bank of the device consist of two single-ended output drivers and two single-ended input buffers (for ratioed inputs such as LVCMOS and LVTTL). The I/O pairs on the bottom also have differential input buffers. Only the I/Os on the bottom banks have programmable PCI clamps and differential input termination. The PCI clamp is enabled after V_{CC} and V_{CCIO} are at valid operating levels and the device has been configured.

3. Top sysIO Buffer Pairs

The sysIO buffer pairs in the top bank of the device consist of two single-ended output drivers and two single-ended input buffers (for ratioed inputs such as LVCMOS and LVTTL). The I/O pairs on the top also have differential I/O buffers. Half of the sysIO buffer pairs on the top edge have true differential outputs. The sysIO buffer pair comprising of the A and B PIOs in every PIC on the top edge have a differential output driver.

Typical I/O Behavior During Power-up

The internal power-on-reset (POR) signal is deactivated when V_{CC} and V_{CCIO0} have reached V_{PORUP} level defined in the Power-On-Reset Voltage table in the DC and Switching Characteristics section of this data sheet. After the POR signal is deactivated, the FPGA core logic becomes active. It is the user's responsibility to ensure that all V_{CCIO} banks are active with valid input logic levels to properly control the output logic states of all the I/O banks that are critical to the application. The default configuration of the I/O pins in a blank device is tri-state with a weak pull-down to GND (some pins such as PROGRAMN and the JTAG pins have weak pull-up to V_{CCIO} as the default functionality). The I/O pins will maintain the blank configuration until V_{CC} and V_{CCIO} (for I/O banks containing configuration I/Os) have reached V_{PORUP} levels at which time the I/Os will take on the user-configured settings only after a proper download/configuration.

There are various ways a user can ensure that there are no spurious signals on critical outputs as the device powers up. These are discussed in more detail in TN1280, [MachXO3 sysIO Usage Guide](#).

Supported Standards

The MachXO3L/LF sysIO buffer supports both single-ended and differential standards. Single-ended standards can be further subdivided into LVCMOS, LVTTL, and PCI. The buffer supports the LVTTL, PCI, LVCMOS 1.2 V, 1.5 V, 1.8 V, 2.5 V, and 3.3 V standards. In the LVCMOS and LVTTL modes, the buffer has individually configurable options for drive strength, bus maintenance (weak pull-up, weak pull-down, bus-keeper latch or none) and open drain. BLVDS, MLVDS and LVPECL output emulation is supported on all devices. The MachXO3L/LF devices support on-chip LVDS output buffers on approximately 50% of the I/Os on the top bank. Differential receivers for LVDS, BLVDS, MLVDS and LVPECL are supported on all banks of MachXO3L/LF devices. PCI support is provided in the bottom bank of the MachXO3L/LF devices. Table 2-11 summarizes the I/O characteristics of the MachXO3L/LF PLDs.

Figure 2-15. MachXO3L/LF-1300 in 256 Ball Packages, MachXO3L/LF-2100, MachXO3L/LF-4300, MachXO3L/LF-6900 and MachXO3L/LF-9400 Banks

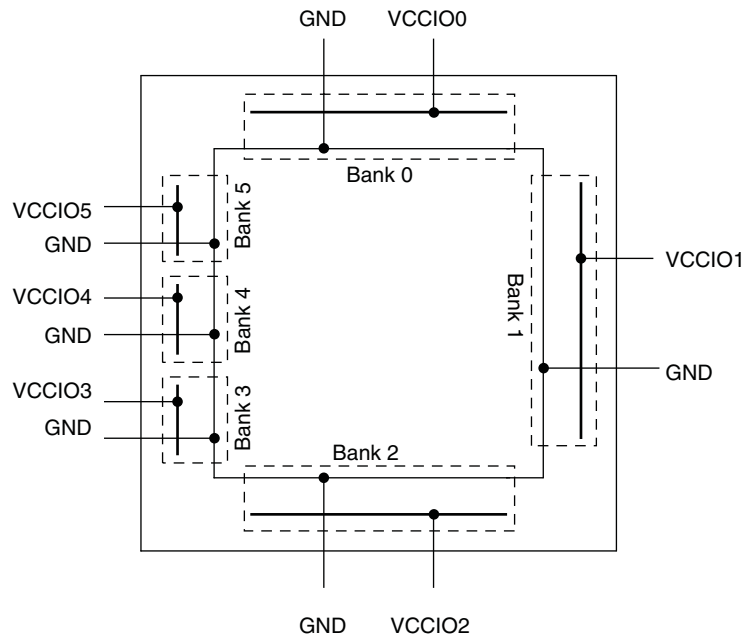
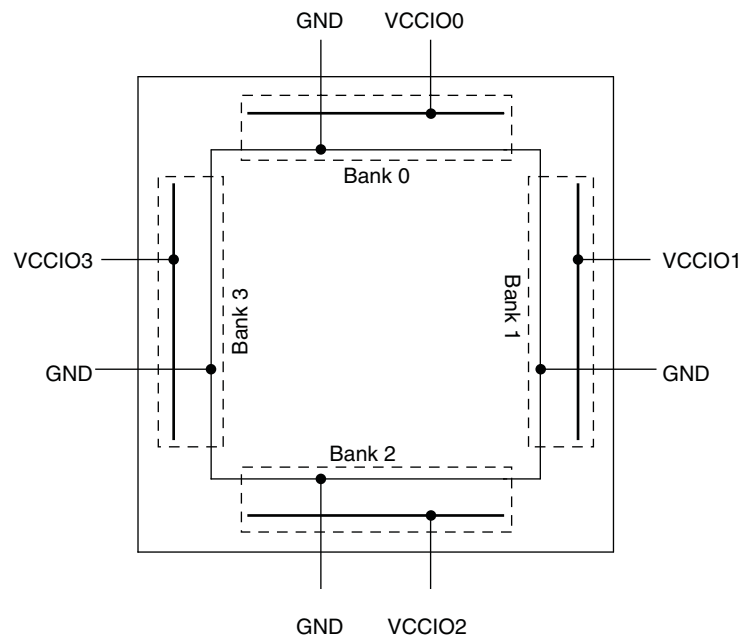

Figure 2-16. MachXO3L/LF-640 and MachXO3L/LF-1300 Banks



Static Supply Current – C/E Devices^{1, 2, 3, 6}

Symbol	Parameter	Device	Typ. ⁴	Units
I _{CC}	Core Power Supply	LCMXO3L/LF-1300C 256 Ball Package	4.8	mA
		LCMXO3L/LF-2100C	4.8	mA
		LCMXO3L/LF-2100C 324 Ball Package	8.45	mA
		LCMXO3L/LF-4300C	8.45	mA
		LCMXO3L/LF-4300C 400 Ball Package	12.87	mA
		LCMXO3L/LF-6900C ⁷	12.87	mA
		LCMXO3L/LF-9400C ⁷	17.86	mA
		LCMXO3L/LF-640E	1.00	mA
		LCMXO3L/LF-1300E	1.00	mA
		LCMXO3L/LF-1300E 256 Ball Package	1.39	mA
		LCMXO3L/LF-2100E	1.39	mA
		LCMXO3L/LF-2100E 324 Ball Package	2.55	mA
		LCMXO3L/LF-4300E	2.55	mA
		LCMXO3L/LF-6900E	4.06	mA
LCMXO3L/LF-9400E	5.66	mA		
I _{CCIO}	Bank Power Supply ⁵ V _{CCIO} = 2.5 V	All devices	0	mA

1. For further information on supply current, please refer to TN1289, [Power Estimation and Management for MachXO3 Devices](#).
2. Assumes blank pattern with the following characteristics: all outputs are tri-stated, all inputs are configured as LVCMOS and held at V_{CCIO} or GND, on-chip oscillator is off, on-chip PLL is off.
3. Frequency = 0 MHz.
4. T_J = 25 °C, power supplies at nominal voltage.
5. Does not include pull-up/pull-down.
6. To determine the MachXO3L/LF peak start-up current data, use the Power Calculator tool.
7. Determination of safe ambient operating conditions requires use of the Diamond Power Calculator tool.

Programming and Erase Supply Current – C/E Devices^{1, 2, 3, 4}

Symbol	Parameter	Device	Typ. ⁴	Units
I _{CC}	Core Power Supply	LCMXO3L/LF-1300C 256 Ball Package	22.1	mA
		LCMXO3L/LF-2100C	22.1	mA
		LCMXO3L/LF-2100C 324 Ball Package	26.8	mA
		LCMXO3L/LF-4300C	26.8	mA
		LCMXO3L/LF-4300C 400 Ball Package	33.2	mA
		LCMXO3L/LF-6900C	33.2	mA
		LCMXO3L/LF-9400C	39.6	mA
		LCMXO3L/LF-640E	17.7	mA
		LCMXO3L/LF-1300E	17.7	mA
		LCMXO3L/LF-1300E 256 Ball Package	18.3	mA
		LCMXO3L/LF-2100E	18.3	mA
		LCMXO3L/LF-2100E 324 Ball Package	20.4	mA
		LCMXO3L/LF-4300E	20.4	mA
		LCMXO3L/LF-6900E	23.9	mA
		LCMXO3L/LF-9400E	28.5	mA
I _{CCIO}	Bank Power Supply ⁵ V _{CCIO} = 2.5 V	All devices	0	mA

1. For further information on supply current, please refer to TN1289, [Power Estimation and Management for MachXO3 Devices](#).
2. Assumes all inputs are held at V_{CCIO} or GND and all outputs are tri-stated.
3. Typical user pattern.
4. JTAG programming is at 25 MHz.
5. T_J = 25 °C, power supplies at nominal voltage.
6. Per bank. V_{CCIO} = 2.5 V. Does not include pull-up/pull-down.

LVDS Emulation

MachXO3L/LF devices can support LVDS outputs via emulation (LVDS25E). The output is emulated using complementary LVC MOS outputs in conjunction with resistors across the driver outputs on all devices. The scheme shown in Figure 3-1 is one possible solution for LVDS standard implementation. Resistor values in Figure 3-1 are industry standard values for 1% resistors.

Figure 3-1. LVDS Using External Resistors (LVDS25E)

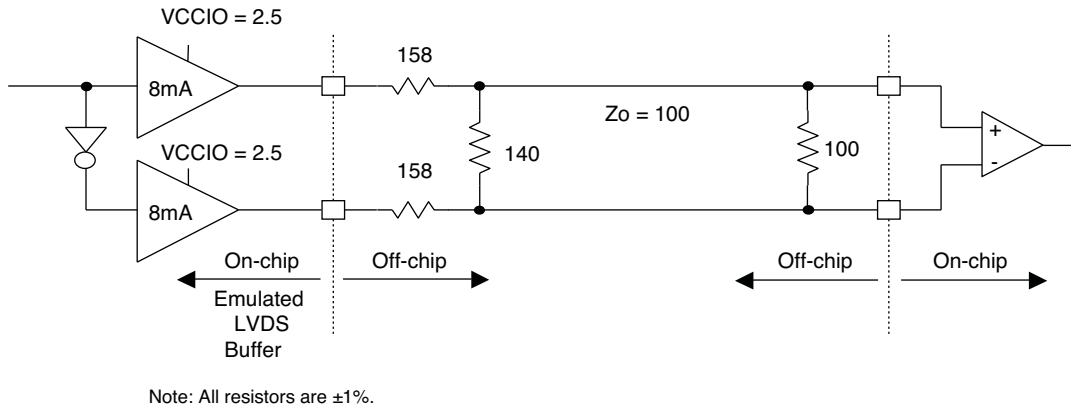

Table 3-1. LVDS25E DC Conditions

Over Recommended Operating Conditions

Parameter	Description	Typ.	Units
Z_{OUT}	Output impedance	20	Ohms
R_S	Driver series resistor	158	Ohms
R_P	Driver parallel resistor	140	Ohms
R_T	Receiver termination	100	Ohms
V_{OH}	Output high voltage	1.43	V
V_{OL}	Output low voltage	1.07	V
V_{OD}	Output differential voltage	0.35	V
V_{CM}	Output common mode voltage	1.25	V
Z_{BACK}	Back impedance	100.5	Ohms
I_{DC}	DC output current	6.03	mA

Typical Building Block Function Performance – C/E Devices¹

Pin-to-Pin Performance (LVCMOS25 12 mA Drive)

Function	–6 Timing	Units
Basic Functions		
16-bit decoder	8.9	ns
4:1 MUX	7.5	ns
16:1 MUX	8.3	ns

Register-to-Register Performance

Function	–6 Timing	Units
Basic Functions		
16:1 MUX	412	MHz
16-bit adder	297	MHz
16-bit counter	324	MHz
64-bit counter	161	MHz
Embedded Memory Functions		
1024x9 True-Dual Port RAM (Write Through or Normal, EBR output registers)	183	MHz
Distributed Memory Functions		
16x4 Pseudo-Dual Port RAM (one PFU)	500	MHz

1. The above timing numbers are generated using the Diamond design tool. Exact performance may vary with device and tool version. The tool uses internal parameters that have been characterized but are not tested on every device. Commercial timing numbers are shown at 85 °C and 1.14 V. Other operating conditions, including industrial, can be extracted from the Diamond software.

Derating Logic Timing

Logic timing provided in the following sections of the data sheet and the Lattice design tools are worst case numbers in the operating range. Actual delays may be much faster. Lattice design tools can provide logic timing numbers at a particular temperature and voltage.

Parameter	Description	Device	-6		-5		Units
			Min.	Max.	Min.	Max.	
MIPI D-PHY Inputs with Clock and Data Centered at Pin Using PCLK Pin for Clock Input - GDDR4_RX.ECLK.Centered^{10, 11, 12}							
t_{SU}^{15}	Input Data Setup Before ECLK	All MachXO3L/LF devices, bottom side only	0.200	—	0.200	—	UI
t_{HO}^{15}	Input Data Hold After ECLK		0.200	—	0.200	—	UI
f_{DATA}^{14}	MIPI D-PHY Input Data Speed		—	900	—	900	Mbps
f_{DDR4}^{14}	MIPI D-PHY ECLK Frequency		—	450	—	450	MHz
f_{SCLK}^{14}	SCLK Frequency		—	112.5	—	112.5	MHz
Generic DDR Outputs with Clock and Data Aligned at Pin Using PCLK Pin for Clock Input – GDDR1_TX.SCLK.Aligned⁸							
t_{DIA}	Output Data Invalid After CLK Output	All MachXO3L/LF devices, all sides	—	0.520	—	0.550	ns
t_{DIB}	Output Data Invalid Before CLK Output		—	0.520	—	0.550	ns
f_{DATA}	DDR1 Output Data Speed		—	300	—	250	Mbps
f_{DDR1}	DDR1 SCLK frequency		—	150	—	125	MHz
Generic DDR Outputs with Clock and Data Centered at Pin Using PCLK Pin for Clock Input – GDDR1_TX.SCLK.Centered⁸							
t_{DVB}	Output Data Valid Before CLK Output	All MachXO3L/LF devices, all sides	1.210	—	1.510	—	ns
t_{DVA}	Output Data Valid After CLK Output		1.210	—	1.510	—	ns
f_{DATA}	DDR1 Output Data Speed		—	300	—	250	Mbps
f_{DDR1}	DDR1 SCLK Frequency (minimum limited by PLL)		—	150	—	125	MHz
Generic DDR2 Outputs with Clock and Data Aligned at Pin Using PCLK Pin for Clock Input – GDDR2_TX.ECLK.Aligned⁸							
t_{DIA}	Output Data Invalid After CLK Output	MachXO3L/LF devices, top side only	—	0.200	—	0.215	ns
t_{DIB}	Output Data Invalid Before CLK Output		—	0.200	—	0.215	ns
f_{DATA}	DDR2 Serial Output Data Speed		—	664	—	554	Mbps
f_{DDR2}	DDR2 ECLK frequency		—	332	—	277	MHz
f_{SCLK}	SCLK Frequency		—	166	—	139	MHz
Generic DDR2 Outputs with Clock and Data Centered at Pin Using PCLK Pin for Clock Input – GDDR2_TX.ECLK.Centered^{8, 9}							
t_{DVB}	Output Data Valid Before CLK Output	MachXO3L/LF devices, top side only	0.535	—	0.670	—	ns
t_{DVA}	Output Data Valid After CLK Output		0.535	—	0.670	—	ns
f_{DATA}	DDR2 Serial Output Data Speed		—	664	—	554	Mbps
f_{DDR2}	DDR2 ECLK Frequency (minimum limited by PLL)		—	332	—	277	MHz
f_{SCLK}	SCLK Frequency		—	166	—	139	MHz
Generic DDR4 Outputs with Clock and Data Aligned at Pin Using PCLK Pin for Clock Input – GDDR4_TX.ECLK.Aligned^{8, 9}							
t_{DIA}	Output Data Invalid After CLK Output	MachXO3L/LF devices, top side only	—	0.200	—	0.215	ns
t_{DIB}	Output Data Invalid Before CLK Output		—	0.200	—	0.215	ns
f_{DATA}	DDR4 Serial Output Data Speed		—	800	—	630	Mbps
f_{DDR4}	DDR4 ECLK Frequency		—	400	—	315	MHz
f_{SCLK}	SCLK Frequency		—	100	—	79	MHz

	MachXO3L/LF-4300						
	WLCSP81	CSFBGA121	CSFBGA256	CSFBGA324	CABGA256	CABGA324	CABGA400
General Purpose IO per Bank							
Bank 0	29	24	50	71	50	71	83
Bank 1	0	26	52	62	52	68	84
Bank 2	20	26	52	72	52	72	84
Bank 3	7	7	16	22	16	24	28
Bank 4	0	7	16	14	16	16	24
Bank 5	7	10	20	27	20	28	32
Total General Purpose Single Ended IO	63	100	206	268	206	279	335
Differential IO per Bank							
Bank 0	15	12	25	36	25	36	42
Bank 1	0	13	26	30	26	34	42
Bank 2	10	13	26	36	26	36	42
Bank 3	3	3	8	10	8	12	14
Bank 4	0	3	8	6	8	8	12
Bank 5	3	5	10	13	10	14	16
Total General Purpose Differential IO	31	49	103	131	103	140	168
Dual Function IO	25	37	37	37	37	37	37
Number 7:1 or 8:1 Gearboxes							
Number of 7:1 or 8:1 Output Gearbox Available (Bank 0)	10	7	18	18	18	18	21
Number of 7:1 or 8:1 Input Gearbox Available (Bank 2)	10	13	18	18	18	18	21
High-speed Differential Outputs							
Bank 0	10	7	18	18	18	18	21
VCCIO Pins							
Bank 0	3	1	4	4	4	4	5
Bank 1	0	1	3	4	4	4	5
Bank 2	2	1	4	4	4	4	5
Bank 3	1	1	2	2	1	2	2
Bank 4	0	1	2	2	2	2	2
Bank 5	1	1	2	2	1	2	2
VCC	4	4	8	8	8	10	10
GND	6	10	24	16	24	16	33
NC	0	0	0	13	1	0	0
Reserved for Configuration	1	1	1	1	1	1	1
Total Count of Bonded Pins	81	121	256	324	256	324	400

	MachXO3L/LF-6900				
	CSFBGA256	CSFBGA324	CABGA256	CABGA324	CABGA400
General Purpose IO per Bank					
Bank 0	50	73	50	71	83
Bank 1	52	68	52	68	84
Bank 2	52	72	52	72	84
Bank 3	16	24	16	24	28
Bank 4	16	16	16	16	24
Bank 5	20	28	20	28	32
Total General Purpose Single Ended IO	206	281	206	279	335
Differential IO per Bank					
Bank 0	25	36	25	36	42
Bank 1	26	34	26	34	42
Bank 2	26	36	26	36	42
Bank 3	8	12	8	12	14
Bank 4	8	8	8	8	12
Bank 5	10	14	10	14	16
Total General Purpose Differential IO	103	140	103	140	168
Dual Function IO	37	37	37	37	37
Number 7:1 or 8:1 Gearboxes					
Number of 7:1 or 8:1 Output Gearbox Available (Bank 0)	20	21	20	21	21
Number of 7:1 or 8:1 Input Gearbox Available (Bank 2)	20	21	20	21	21
High-speed Differential Outputs					
Bank 0	20	21	20	21	21
VCCIO Pins					
Bank 0	4	4	4	4	5
Bank 1	3	4	4	4	5
Bank 2	4	4	4	4	5
Bank 3	2	2	1	2	2
Bank 4	2	2	2	2	2
Bank 5	2	2	1	2	2
VCC	8	8	8	10	10
GND	24	16	24	16	33
NC	0	0	1	0	0
Reserved for Configuration	1	1	1	1	1
Total Count of Bonded Pins	256	324	256	324	400

MachXO3 Part Number Description

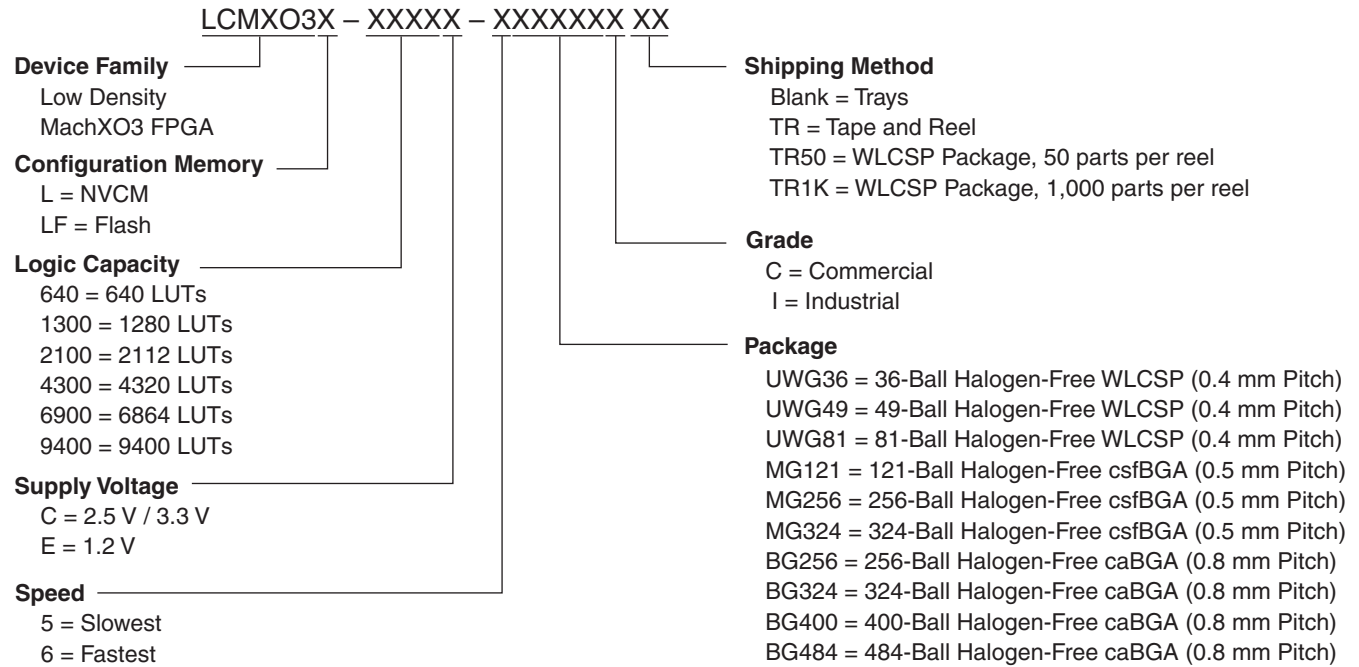

Ordering Information

MachXO3L/LF devices have top-side markings as shown in the examples below, on the 256-Ball caBGA package with MachXO3-6900 device in Commercial Temperature in Speed Grade 5. Notice that for the MachXO3LF device, *LMXO3LF* is used instead of *LCMXO3LF* as in the Part Number.



Note: *LCMXO3LF* is marked with *LMXO3LF*

Note: Markings are abbreviated for small packages.

MachXO3L Ultra Low Power Commercial and Industrial Grade Devices, Halogen Free (RoHS) Packaging

Part Number	LUTs	Supply Voltage	Speed	Package	Leads	Temp.
LCMXO3L-640E-5MG121C	640	1.2 V	5	Halogen-Free csfBGA	121	COM
LCMXO3L-640E-6MG121C	640	1.2 V	6	Halogen-Free csfBGA	121	COM
LCMXO3L-640E-5MG121I	640	1.2 V	5	Halogen-Free csfBGA	121	IND
LCMXO3L-640E-6MG121I	640	1.2 V	6	Halogen-Free csfBGA	121	IND

Part Number	LUTs	Supply Voltage	Speed	Package	Leads	Temp.
LCMXO3L-1300E-5UWG36CTR	1300	1.2 V	5	Halogen-Free WLCSP	36	COM
LCMXO3L-1300E-5UWG36CTR50	1300	1.2 V	5	Halogen-Free WLCSP	36	COM
LCMXO3L-1300E-5UWG36CTR1K	1300	1.2 V	5	Halogen-Free WLCSP	36	COM
LCMXO3L-1300E-5UWG36ITR	1300	1.2 V	5	Halogen-Free WLCSP	36	IND
LCMXO3L-1300E-5UWG36ITR50	1300	1.2 V	5	Halogen-Free WLCSP	36	IND
LCMXO3L-1300E-5UWG36ITR1K	1300	1.2 V	5	Halogen-Free WLCSP	36	IND
LCMXO3L-1300E-5MG121C	1300	1.2 V	5	Halogen-Free csfBGA	121	COM
LCMXO3L-1300E-6MG121C	1300	1.2 V	6	Halogen-Free csfBGA	121	COM
LCMXO3L-1300E-5MG121I	1300	1.2 V	5	Halogen-Free csfBGA	121	IND
LCMXO3L-1300E-6MG121I	1300	1.2 V	6	Halogen-Free csfBGA	121	IND
LCMXO3L-1300E-5MG256C	1300	1.2 V	5	Halogen-Free csfBGA	256	COM
LCMXO3L-1300E-6MG256C	1300	1.2 V	6	Halogen-Free csfBGA	256	COM
LCMXO3L-1300E-5MG256I	1300	1.2 V	5	Halogen-Free csfBGA	256	IND
LCMXO3L-1300E-6MG256I	1300	1.2 V	6	Halogen-Free csfBGA	256	IND
LCMXO3L-1300C-5BG256C	1300	2.5 V / 3.3 V	5	Halogen-Free caBGA	256	COM
LCMXO3L-1300C-6BG256C	1300	2.5 V / 3.3 V	6	Halogen-Free caBGA	256	COM
LCMXO3L-1300C-5BG256I	1300	2.5 V / 3.3 V	5	Halogen-Free caBGA	256	IND
LCMXO3L-1300C-6BG256I	1300	2.5 V / 3.3 V	6	Halogen-Free caBGA	256	IND

Part Number	LUTs	Supply Voltage	Speed	Package	Leads	Temp.
LCMXO3L-2100E-5UWG49CTR	2100	1.2 V	5	Halogen-Free WLCSP	49	COM
LCMXO3L-2100E-5UWG49CTR50	2100	1.2 V	5	Halogen-Free WLCSP	49	COM
LCMXO3L-2100E-5UWG49CTR1K	2100	1.2 V	5	Halogen-Free WLCSP	49	COM
LCMXO3L-2100E-5UWG49ITR	2100	1.2 V	5	Halogen-Free WLCSP	49	IND
LCMXO3L-2100E-5UWG49ITR50	2100	1.2 V	5	Halogen-Free WLCSP	49	IND
LCMXO3L-2100E-5UWG49ITR1K	2100	1.2 V	5	Halogen-Free WLCSP	49	IND
LCMXO3L-2100E-5MG121C	2100	1.2 V	5	Halogen-Free csfBGA	121	COM
LCMXO3L-2100E-6MG121C	2100	1.2 V	6	Halogen-Free csfBGA	121	COM
LCMXO3L-2100E-5MG121I	2100	1.2 V	5	Halogen-Free csfBGA	121	IND
LCMXO3L-2100E-6MG121I	2100	1.2 V	6	Halogen-Free csfBGA	121	IND
LCMXO3L-2100E-5MG256C	2100	1.2 V	5	Halogen-Free csfBGA	256	COM
LCMXO3L-2100E-6MG256C	2100	1.2 V	6	Halogen-Free csfBGA	256	COM
LCMXO3L-2100E-5MG256I	2100	1.2 V	5	Halogen-Free csfBGA	256	IND
LCMXO3L-2100E-6MG256I	2100	1.2 V	6	Halogen-Free csfBGA	256	IND
LCMXO3L-2100E-5MG324C	2100	1.2 V	5	Halogen-Free csfBGA	324	COM
LCMXO3L-2100E-6MG324C	2100	1.2 V	6	Halogen-Free csfBGA	324	COM
LCMXO3L-2100E-5MG324I	2100	1.2 V	5	Halogen-Free csfBGA	324	IND

Part Number	LUTs	Supply Voltage	Speed	Package	Leads	Temp.
LCMXO3L-2100E-6MG324I	2100	1.2 V	6	Halogen-Free csfBGA	324	IND
LCMXO3L-2100C-5BG256C	2100	2.5 V / 3.3 V	5	Halogen-Free caBGA	256	COM
LCMXO3L-2100C-6BG256C	2100	2.5 V / 3.3 V	6	Halogen-Free caBGA	256	COM
LCMXO3L-2100C-5BG256I	2100	2.5 V / 3.3 V	5	Halogen-Free caBGA	256	IND
LCMXO3L-2100C-6BG256I	2100	2.5 V / 3.3 V	6	Halogen-Free caBGA	256	IND
LCMXO3L-2100C-5BG324C	2100	2.5 V / 3.3 V	5	Halogen-Free caBGA	324	COM
LCMXO3L-2100C-6BG324C	2100	2.5 V / 3.3 V	6	Halogen-Free caBGA	324	COM
LCMXO3L-2100C-5BG324I	2100	2.5 V / 3.3 V	5	Halogen-Free caBGA	324	IND
LCMXO3L-2100C-6BG324I	2100	2.5 V / 3.3 V	6	Halogen-Free caBGA	324	IND

Part Number	LUTs	Supply Voltage	Speed	Package	Leads	Temp.
LCMXO3L-4300E-5UWG81CTR	4300	1.2 V	5	Halogen-Free WLCSP	81	COM
LCMXO3L-4300E-5UWG81CTR50	4300	1.2 V	5	Halogen-Free WLCSP	81	COM
LCMXO3L-4300E-5UWG81CTR1K	4300	1.2 V	5	Halogen-Free WLCSP	81	COM
LCMXO3L-4300E-5UWG81ITR	4300	1.2 V	5	Halogen-Free WLCSP	81	IND
LCMXO3L-4300E-5UWG81ITR50	4300	1.2 V	5	Halogen-Free WLCSP	81	IND
LCMXO3L-4300E-5UWG81ITR1K	4300	1.2 V	5	Halogen-Free WLCSP	81	IND
LCMXO3L-4300E-5MG121C	4300	1.2 V	5	Halogen-Free csfBGA	121	COM
LCMXO3L-4300E-6MG121C	4300	1.2 V	6	Halogen-Free csfBGA	121	COM
LCMXO3L-4300E-5MG121I	4300	1.2 V	5	Halogen-Free csfBGA	121	IND
LCMXO3L-4300E-6MG121I	4300	1.2 V	6	Halogen-Free csfBGA	121	IND
LCMXO3L-4300E-5MG256C	4300	1.2 V	5	Halogen-Free csfBGA	256	COM
LCMXO3L-4300E-6MG256C	4300	1.2 V	6	Halogen-Free csfBGA	256	COM
LCMXO3L-4300E-5MG256I	4300	1.2 V	5	Halogen-Free csfBGA	256	IND
LCMXO3L-4300E-6MG256I	4300	1.2 V	6	Halogen-Free csfBGA	256	IND
LCMXO3L-4300E-5MG324C	4300	1.2 V	5	Halogen-Free csfBGA	324	COM
LCMXO3L-4300E-6MG324C	4300	1.2 V	6	Halogen-Free csfBGA	324	COM
LCMXO3L-4300E-5MG324I	4300	1.2 V	5	Halogen-Free csfBGA	324	IND
LCMXO3L-4300E-6MG324I	4300	1.2 V	6	Halogen-Free csfBGA	324	IND
LCMXO3L-4300C-5BG256C	4300	2.5 V / 3.3 V	5	Halogen-Free caBGA	256	COM
LCMXO3L-4300C-6BG256C	4300	2.5 V / 3.3 V	6	Halogen-Free caBGA	256	COM
LCMXO3L-4300C-5BG256I	4300	2.5 V / 3.3 V	5	Halogen-Free caBGA	256	IND
LCMXO3L-4300C-6BG256I	4300	2.5 V / 3.3 V	6	Halogen-Free caBGA	256	IND
LCMXO3L-4300C-5BG324C	4300	2.5 V / 3.3 V	5	Halogen-Free caBGA	324	COM
LCMXO3L-4300C-6BG324C	4300	2.5 V / 3.3 V	6	Halogen-Free caBGA	324	COM
LCMXO3L-4300C-5BG324I	4300	2.5 V / 3.3 V	5	Halogen-Free caBGA	324	IND
LCMXO3L-4300C-6BG324I	4300	2.5 V / 3.3 V	6	Halogen-Free caBGA	324	IND
LCMXO3L-4300C-5BG400C	4300	2.5 V / 3.3 V	5	Halogen-Free caBGA	400	COM
LCMXO3L-4300C-6BG400C	4300	2.5 V / 3.3 V	6	Halogen-Free caBGA	400	COM
LCMXO3L-4300C-5BG400I	4300	2.5 V / 3.3 V	5	Halogen-Free caBGA	400	IND
LCMXO3L-4300C-6BG400I	4300	2.5 V / 3.3 V	6	Halogen-Free caBGA	400	IND

Part Number	LUTs	Supply Voltage	Speed	Package	Leads	Temp.
LCMXO3LF-2100E-6MG324I	2100	1.2 V	6	Halogen-Free csfBGA	324	IND
LCMXO3LF-2100C-5BG256C	2100	2.5 V / 3.3 V	5	Halogen-Free caBGA	256	COM
LCMXO3LF-2100C-6BG256C	2100	2.5 V / 3.3 V	6	Halogen-Free caBGA	256	COM
LCMXO3LF-2100C-5BG256I	2100	2.5 V / 3.3 V	5	Halogen-Free caBGA	256	IND
LCMXO3LF-2100C-6BG256I	2100	2.5 V / 3.3 V	6	Halogen-Free caBGA	256	IND
LCMXO3LF-2100C-5BG324C	2100	2.5 V / 3.3 V	5	Halogen-Free caBGA	324	COM
LCMXO3LF-2100C-6BG324C	2100	2.5 V / 3.3 V	6	Halogen-Free caBGA	324	COM
LCMXO3LF-2100C-5BG324I	2100	2.5 V / 3.3 V	5	Halogen-Free caBGA	324	IND
LCMXO3LF-2100C-6BG324I	2100	2.5 V / 3.3 V	6	Halogen-Free caBGA	324	IND

Part Number	LUTs	Supply Voltage	Speed	Package	Leads	Temp.
LCMXO3LF-4300E-5UWG81CTR	4300	1.2 V	5	Halogen-Free WLCSP	81	COM
LCMXO3LF-4300E-5UWG81CTR50	4300	1.2 V	5	Halogen-Free WLCSP	81	COM
LCMXO3LF-4300E-5UWG81CTR1K	4300	1.2 V	5	Halogen-Free WLCSP	81	COM
LCMXO3LF-4300E-5UWG81ITR	4300	1.2 V	5	Halogen-Free WLCSP	81	IND
LCMXO3LF-4300E-5UWG81ITR50	4300	1.2 V	5	Halogen-Free WLCSP	81	IND
LCMXO3LF-4300E-5UWG81ITR1K	4300	1.2 V	5	Halogen-Free WLCSP	81	IND
LCMXO3LF-4300E-5MG121C	4300	1.2 V	5	Halogen-Free csfBGA	121	COM
LCMXO3LF-4300E-6MG121C	4300	1.2 V	6	Halogen-Free csfBGA	121	COM
LCMXO3LF-4300E-5MG121I	4300	1.2 V	5	Halogen-Free csfBGA	121	IND
LCMXO3LF-4300E-6MG121I	4300	1.2 V	6	Halogen-Free csfBGA	121	IND
LCMXO3LF-4300E-5MG256C	4300	1.2 V	5	Halogen-Free csfBGA	256	COM
LCMXO3LF-4300E-6MG256C	4300	1.2 V	6	Halogen-Free csfBGA	256	COM
LCMXO3LF-4300E-5MG256I	4300	1.2 V	5	Halogen-Free csfBGA	256	IND
LCMXO3LF-4300E-6MG256I	4300	1.2 V	6	Halogen-Free csfBGA	256	IND
LCMXO3LF-4300E-5MG324C	4300	1.2 V	5	Halogen-Free csfBGA	324	COM
LCMXO3LF-4300E-6MG324C	4300	1.2 V	6	Halogen-Free csfBGA	324	COM
LCMXO3LF-4300E-5MG324I	4300	1.2 V	5	Halogen-Free csfBGA	324	IND
LCMXO3LF-4300E-6MG324I	4300	1.2 V	6	Halogen-Free csfBGA	324	IND
LCMXO3LF-4300C-5BG256C	4300	2.5 V / 3.3 V	5	Halogen-Free caBGA	256	COM
LCMXO3LF-4300C-6BG256C	4300	2.5 V / 3.3 V	6	Halogen-Free caBGA	256	COM
LCMXO3LF-4300C-5BG256I	4300	2.5 V / 3.3 V	5	Halogen-Free caBGA	256	IND
LCMXO3LF-4300C-6BG256I	4300	2.5 V / 3.3 V	6	Halogen-Free caBGA	256	IND
LCMXO3LF-4300C-5BG324C	4300	2.5 V / 3.3 V	5	Halogen-Free caBGA	324	COM
LCMXO3LF-4300C-6BG324C	4300	2.5 V / 3.3 V	6	Halogen-Free caBGA	324	COM
LCMXO3LF-4300C-5BG324I	4300	2.5 V / 3.3 V	5	Halogen-Free caBGA	324	IND
LCMXO3LF-4300C-6BG324I	4300	2.5 V / 3.3 V	6	Halogen-Free caBGA	324	IND
LCMXO3LF-4300C-5BG400C	4300	2.5 V / 3.3 V	5	Halogen-Free caBGA	400	COM
LCMXO3LF-4300C-6BG400C	4300	2.5 V / 3.3 V	6	Halogen-Free caBGA	400	COM
LCMXO3LF-4300C-5BG400I	4300	2.5 V / 3.3 V	5	Halogen-Free caBGA	400	IND
LCMXO3LF-4300C-6BG400I	4300	2.5 V / 3.3 V	6	Halogen-Free caBGA	400	IND

Date	Version	Section	Change Summary
February 2017	1.8	Architecture	Updated Supported Standards section. Corrected “MDVS” to “MLDVS” in Table 2-11, Supported Input Standards.
		DC and Switching Characteristics	Updated ESD Performance section. Added reference to the MachXO2 Product Family Qualification Summary document.
			Updated Static Supply Current – C/E Devices section. Added footnote 7.
			Updated MachXO3L/LF External Switching Characteristics – C/E Devices section. — Populated values for MachXO3L/LF-9400. — Under 7:1 LVDS Outputs – GDDR71_TX.ECLK.7:1, corrected “t _{DVB} ” to “t _{DIB} ” and “t _{DVA} ” to “t _{DIA} ” and revised their descriptions. — Added Figure 3-6, Receiver GDDR71_RX Waveforms and Figure 3-7, Transmitter GDDR71_TX Waveforms.
Pinout Information	Updated the Pin Information Summary section. Added MachXO3L/LF-9600C packages.		
May 2016	1.7	DC and Switching Characteristics	Updated Absolute Maximum Ratings section. Modified I/O Tri-state Voltage Applied and Dedicated Input Voltage Applied footnotes.
			Updated sysIO Recommended Operating Conditions section. — Added standards. — Added V _{REF} (V) — Added footnote 4.
			Updated sysIO Single-Ended DC Electrical Characteristics section. Added I/O standards.
		Ordering Information	Updated MachXO3L Ultra Low Power Commercial and Industrial Grade Devices, Halogen Free (RoHS) Packaging section. Added LCMXO3L-9400C part numbers.
Updated MachXO3LF Ultra Low Power Commercial and Industrial Grade Devices, Halogen Free (RoHS) Packaging section. Added LCMXO3L-9400C part numbers.			