

Welcome to [E-XFL.COM](https://www.e-xfl.com)

Understanding **Embedded - FPGAs (Field Programmable Gate Array)**

Embedded - FPGAs, or Field Programmable Gate Arrays, are advanced integrated circuits that offer unparalleled flexibility and performance for digital systems. Unlike traditional fixed-function logic devices, FPGAs can be programmed and reprogrammed to execute a wide array of logical operations, enabling customized functionality tailored to specific applications. This reprogrammability allows developers to iterate designs quickly and implement complex functions without the need for custom hardware.

Applications of Embedded - FPGAs

The versatility of Embedded - FPGAs makes them indispensable in numerous fields. In telecommunications,

Details

Product Status	Active
Number of LABs/CLBs	858
Number of Logic Elements/Cells	6864
Total RAM Bits	245760
Number of I/O	206
Number of Gates	-
Voltage - Supply	1.14V ~ 1.26V
Mounting Type	Surface Mount
Operating Temperature	-40°C ~ 100°C (TJ)
Package / Case	256-VFBGA
Supplier Device Package	256-CSFBGA (9x9)
Purchase URL	https://www.e-xfl.com/product-detail/lattice-semiconductor/lcmx03lf-6900e-5mg256i

Architecture Overview

The MachXO3L/LF family architecture contains an array of logic blocks surrounded by Programmable I/O (PIO). All logic density devices in this family have sysCLOCK™ PLLs and blocks of sysMEM Embedded Block RAM (EBRs). Figure 2-1 and Figure 2-2 show the block diagrams of the various family members.

Figure 2-1. Top View of the MachXO3L/LF-1300 Device

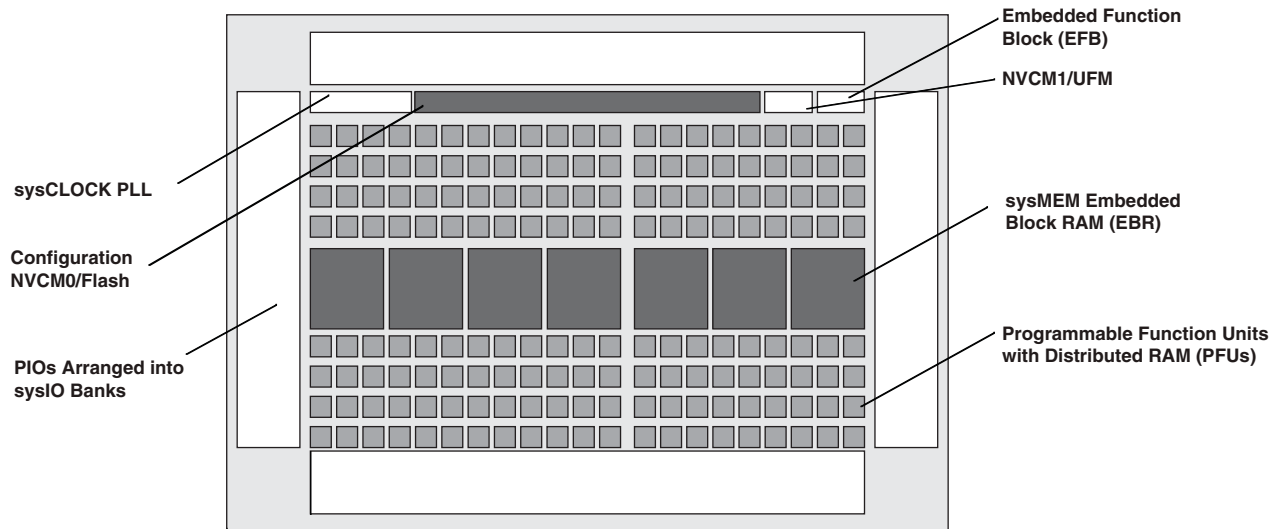

Notes:

- MachXO3L/LF-640 is similar to MachXO3L/LF-1300. MachXO3L/LF-640 has a lower LUT count.
- MachXO3L devices have NVCM, MachXO3LF devices have Flash.

Table 2-6. EBR Signal Descriptions

Port Name	Description	Active State
CLK	Clock	Rising Clock Edge
CE	Clock Enable	Active High
OCE ¹	Output Clock Enable	Active High
RST	Reset	Active High
BE ¹	Byte Enable	Active High
WE	Write Enable	Active High
AD	Address Bus	—
DI	Data In	—
DO	Data Out	—
CS	Chip Select	Active High
AFF	FIFO RAM Almost Full Flag	—
FF	FIFO RAM Full Flag	—
AEF	FIFO RAM Almost Empty Flag	—
EF	FIFO RAM Empty Flag	—
RPRST	FIFO RAM Read Pointer Reset	—

1. Optional signals.
2. For dual port EBR primitives a trailing 'A' or 'B' in the signal name specifies the EBR port A or port B respectively.
3. For FIFO RAM mode primitive, a trailing 'R' or 'W' in the signal name specifies the FIFO read port or write port respectively.
4. For FIFO RAM mode primitive FULLI has the same function as CSW(2) and EMPTYI has the same function as CSR(2).
5. In FIFO mode, CLKW is the write port clock, CSW is the write port chip select, CLKR is the read port clock, CSR is the read port chip select, ORE is the output read enable.

The EBR memory supports three forms of write behavior for single or dual port operation:

1. **Normal** – Data on the output appears only during the read cycle. During a write cycle, the data (at the current address) does not appear on the output. This mode is supported for all data widths.
2. **Write Through** – A copy of the input data appears at the output of the same port. This mode is supported for all data widths.
3. **Read-Before-Write** – When new data is being written, the old contents of the address appears at the output.

FIFO Configuration

The FIFO has a write port with data-in, CEW, WE and CLKW signals. There is a separate read port with data-out, RCE, RE and CLKR signals. The FIFO internally generates Almost Full, Full, Almost Empty and Empty Flags. The Full and Almost Full flags are registered with CLKW. The Empty and Almost Empty flags are registered with CLKR. Table 2-7 shows the range of programming values for these flags.

Table 2-7. Programmable FIFO Flag Ranges

Flag Name	Programming Range
Full (FF)	1 to max (up to 2^N-1)
Almost Full (AF)	1 to Full-1
Almost Empty (AE)	1 to Full-1
Empty (EF)	0

N = Address bit width.

The FIFO state machine supports two types of reset signals: RST and RPRST. The RST signal is a global reset that clears the contents of the FIFO by resetting the read/write pointer and puts the FIFO flags in their initial reset

If an EBR is pre-loaded during configuration, the GSR input must be disabled or the release of the GSR during device wake up must occur before the release of the device I/Os becoming active.

These instructions apply to all EBR RAM, ROM and FIFO implementations. For the EBR FIFO mode, the GSR signal is always enabled and the WE and RE signals act like the clock enable signals in Figure 2-10. The reset timing rules apply to the RPRreset input versus the RE input and the RST input versus the WE and RE inputs. Both RST and RPRreset are always asynchronous EBR inputs. For more details refer to TN1290, [Memory Usage Guide for MachXO3 Devices](#).

Note that there are no reset restrictions if the EBR synchronous reset is used and the EBR GSR input is disabled.

Programmable I/O Cells (PIC)

The programmable logic associated with an I/O is called a PIO. The individual PIO are connected to their respective sysIO buffers and pads. On the MachXO3L/LF devices, the PIO cells are assembled into groups of four PIO cells called a Programmable I/O Cell or PIC. The PICs are placed on all four sides of the device.

On all the MachXO3L/LF devices, two adjacent PIOs can be combined to provide a complementary output driver pair.

All PIO pairs can implement differential receivers. Half of the PIO pairs on the top edge of these devices can be configured as true LVDS transmit pairs. The PIO pairs on the bottom edge of these devices have on-chip differential termination and also provide PCI support.

Input Gearbox

Each PIC on the bottom edge has a built-in 1:8 input gearbox. Each of these input gearboxes may be programmed as a 1:7 de-serializer or as one IDDRX4 (1:8) gearbox or as two IDDRX2 (1:4) gearboxes. Table 2-9 shows the gearbox signals.

Table 2-9. Input Gearbox Signal List

Name	I/O Type	Description
D	Input	High-speed data input after programmable delay in PIO A input register block
ALIGNWD	Input	Data alignment signal from device core
SCLK	Input	Slow-speed system clock
ECLK[1:0]	Input	High-speed edge clock
RST	Input	Reset
Q[7:0]	Output	Low-speed data to device core: Video RX(1:7): Q[6:0] GDDR4(1:8): Q[7:0] GDDR2(1:4)(IOL-A): Q4, Q5, Q6, Q7 GDDR2(1:4)(IOL-C): Q0, Q1, Q2, Q3

These gearboxes have three stage pipeline registers. The first stage registers sample the high-speed input data by the high-speed edge clock on its rising and falling edges. The second stage registers perform data alignment based on the control signals UPDATE and SEL0 from the control block. The third stage pipeline registers pass the data to the device core synchronized to the low-speed system clock. Figure 2-13 shows a block diagram of the input gearbox.

sysIO Buffer

Each I/O is associated with a flexible buffer referred to as a sysIO buffer. These buffers are arranged around the periphery of the device in groups referred to as banks. The sysIO buffers allow users to implement a wide variety of standards that are found in today's systems including LVCMOS, TTL, PCI, LVDS, BLVDS, MLVDS and LVPECL.

Each bank is capable of supporting multiple I/O standards. In the MachXO3L/LF devices, single-ended output buffers, ratioed input buffers (LVTTL, LVCMOS and PCI), differential (LVDS) input buffers are powered using I/O supply voltage (V_{CCIO}). Each sysIO bank has its own V_{CCIO} .

MachXO3L/LF devices contain three types of sysIO buffer pairs.

1. Left and Right sysIO Buffer Pairs

The sysIO buffer pairs in the left and right banks of the device consist of two single-ended output drivers and two single-ended input buffers (for ratioed inputs such as LVCMOS and LVTTL). The I/O pairs on the left and right of the devices also have differential input buffers.

2. Bottom sysIO Buffer Pairs

The sysIO buffer pairs in the bottom bank of the device consist of two single-ended output drivers and two single-ended input buffers (for ratioed inputs such as LVCMOS and LVTTL). The I/O pairs on the bottom also have differential input buffers. Only the I/Os on the bottom banks have programmable PCI clamps and differential input termination. The PCI clamp is enabled after V_{CC} and V_{CCIO} are at valid operating levels and the device has been configured.

3. Top sysIO Buffer Pairs

The sysIO buffer pairs in the top bank of the device consist of two single-ended output drivers and two single-ended input buffers (for ratioed inputs such as LVCMOS and LVTTL). The I/O pairs on the top also have differential I/O buffers. Half of the sysIO buffer pairs on the top edge have true differential outputs. The sysIO buffer pair comprising of the A and B PIOs in every PIC on the top edge have a differential output driver.

Typical I/O Behavior During Power-up

The internal power-on-reset (POR) signal is deactivated when V_{CC} and V_{CCIO0} have reached V_{PORUP} level defined in the Power-On-Reset Voltage table in the DC and Switching Characteristics section of this data sheet. After the POR signal is deactivated, the FPGA core logic becomes active. It is the user's responsibility to ensure that all V_{CCIO} banks are active with valid input logic levels to properly control the output logic states of all the I/O banks that are critical to the application. The default configuration of the I/O pins in a blank device is tri-state with a weak pull-down to GND (some pins such as PROGRAMN and the JTAG pins have weak pull-up to V_{CCIO} as the default functionality). The I/O pins will maintain the blank configuration until V_{CC} and V_{CCIO} (for I/O banks containing configuration I/Os) have reached V_{PORUP} levels at which time the I/Os will take on the user-configured settings only after a proper download/configuration.

There are various ways a user can ensure that there are no spurious signals on critical outputs as the device powers up. These are discussed in more detail in TN1280, [MachXO3 sysIO Usage Guide](#).

Supported Standards

The MachXO3L/LF sysIO buffer supports both single-ended and differential standards. Single-ended standards can be further subdivided into LVCMOS, LVTTL, and PCI. The buffer supports the LVTTL, PCI, LVCMOS 1.2 V, 1.5 V, 1.8 V, 2.5 V, and 3.3 V standards. In the LVCMOS and LVTTL modes, the buffer has individually configurable options for drive strength, bus maintenance (weak pull-up, weak pull-down, bus-keeper latch or none) and open drain. BLVDS, MLVDS and LVPECL output emulation is supported on all devices. The MachXO3L/LF devices support on-chip LVDS output buffers on approximately 50% of the I/Os on the top bank. Differential receivers for LVDS, BLVDS, MLVDS and LVPECL are supported on all banks of MachXO3L/LF devices. PCI support is provided in the bottom bank of the MachXO3L/LF devices. Table 2-11 summarizes the I/O characteristics of the MachXO3L/LF PLDs.

Embedded Hardened IP Functions

All MachXO3L/LF devices provide embedded hardened functions such as SPI, I²C and Timer/Counter. MachXO3LF devices also provide User Flash Memory (UFM). These embedded blocks interface through the WISHBONE interface with routing as shown in Figure 2-17.

Figure 2-17. Embedded Function Block Interface

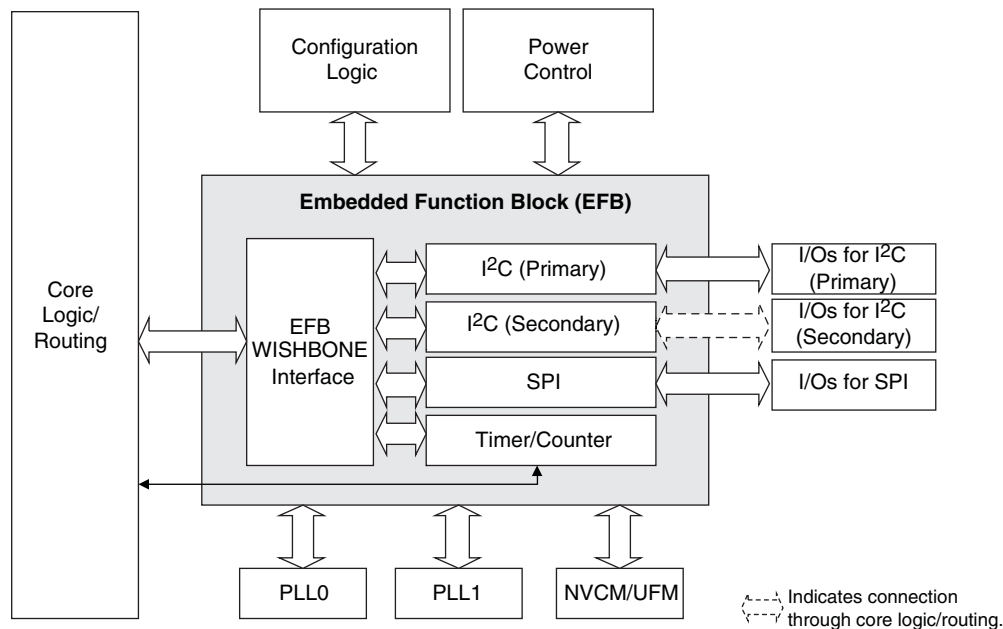

Hardened I²C IP Core

Every MachXO3L/LF device contains two I²C IP cores. These are the primary and secondary I²C IP cores. Either of the two cores can be configured either as an I²C master or as an I²C slave. The only difference between the two IP cores is that the primary core has pre-assigned I/O pins whereas users can assign I/O pins for the secondary core.

When the IP core is configured as a master it will be able to control other devices on the I²C bus through the interface. When the core is configured as the slave, the device will be able to provide I/O expansion to an I²C Master. The I²C cores support the following functionality:

- Master and Slave operation
- 7-bit and 10-bit addressing
- Multi-master arbitration support
- Up to 400 kHz data transfer speed
- General call support
- Interface to custom logic through 8-bit WISHBONE interface

Hardened Timer/Counter

MachXO3L/LF devices provide a hard Timer/Counter IP core. This Timer/Counter is a general purpose, bi-directional, 16-bit timer/counter module with independent output compare units and PWM support. The Timer/Counter supports the following functions:

- Supports the following modes of operation:
 - Watchdog timer
 - Clear timer on compare match
 - Fast PWM
 - Phase and Frequency Correct PWM
- Programmable clock input source
- Programmable input clock prescaler
- One static interrupt output to routing
- One wake-up interrupt to on-chip standby mode controller.
- Three independent interrupt sources: overflow, output compare match, and input capture
- Auto reload
- Time-stamping support on the input capture unit
- Waveform generation on the output
- Glitch-free PWM waveform generation with variable PWM period
- Internal WISHBONE bus access to the control and status registers
- Stand-alone mode with preloaded control registers and direct reset input

Figure 2-20. Timer/Counter Block Diagram

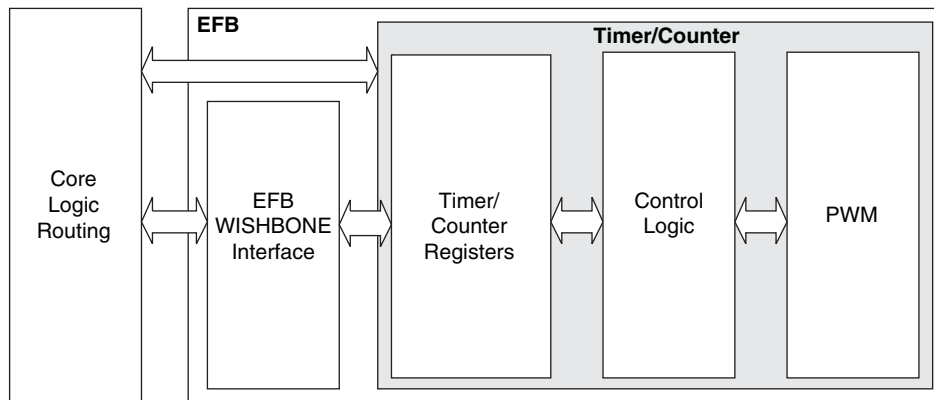

Table 2-16. Timer/Counter Signal Description

Port	I/O	Description
tc_clk	I	Timer/Counter input clock signal
tc_rstn	I	Register tc_rstn_ena is preloaded by configuration to always keep this pin enabled
tc_ic	I	Input capture trigger event, applicable for non-pwm modes with WISHBONE interface. If enabled, a rising edge of this signal will be detected and synchronized to capture tc_cnt value into tc_icr for time-stamping.
tc_int	O	Without WISHBONE – Can be used as overflow flag With WISHBONE – Controlled by three IRQ registers
tc_oc	O	Timer counter output signal

Configuration and Testing

This section describes the configuration and testing features of the MachXO3L/LF family.

IEEE 1149.1-Compliant Boundary Scan Testability

All MachXO3L/LF devices have boundary scan cells that are accessed through an IEEE 1149.1 compliant test access port (TAP). This allows functional testing of the circuit board, on which the device is mounted, through a serial scan path that can access all critical logic nodes. Internal registers are linked internally, allowing test data to be shifted in and loaded directly onto test nodes, or test data to be captured and shifted out for verification. The test access port consists of dedicated I/Os: TDI, TDO, TCK and TMS. The test access port shares its power supply with V_{CCIO} Bank 0 and can operate with LVCMOS3.3, 2.5, 1.8, 1.5, and 1.2 standards.

For more details on boundary scan test, see AN8066, [Boundary Scan Testability with Lattice sysIO Capability](#) and TN1087, [Minimizing System Interruption During Configuration Using TransFR Technology](#).

Device Configuration

All MachXO3L/LF devices contain two ports that can be used for device configuration. The Test Access Port (TAP), which supports bit-wide configuration and the sysCONFIG port which supports serial configuration through I²C or SPI. The TAP supports both the IEEE Standard 1149.1 Boundary Scan specification and the IEEE Standard 1532 In-System Configuration specification. There are various ways to configure a MachXO3L/LF device:

1. Internal NVCM/Flash Download
2. JTAG
3. Standard Serial Peripheral Interface (Master SPI mode) – interface to boot PROM memory
4. System microprocessor to drive a serial slave SPI port (SSPI mode)
5. Standard I²C Interface to system microprocessor

Upon power-up, the configuration SRAM is ready to be configured using the selected sysCONFIG port. Once a configuration port is selected, it will remain active throughout that configuration cycle. The IEEE 1149.1 port can be activated any time after power-up by sending the appropriate command through the TAP port. Optionally the device can run a CRC check upon entering the user mode. This will ensure that the device was configured correctly.

The sysCONFIG port has 10 dual-function pins which can be used as general purpose I/Os if they are not required for configuration. See TN1279, [MachXO3 Programming and Configuration Usage Guide](#) for more information about using the dual-use pins as general purpose I/Os.

Lattice design software uses proprietary compression technology to compress bit-streams for use in MachXO3L/LF devices. Use of this technology allows Lattice to provide a lower cost solution. In the unlikely event that this technology is unable to compress bitstreams to fit into the amount of on-chip NVCM/Flash, there are a variety of techniques that can be utilized to allow the bitstream to fit in the on-chip NVCM/Flash. For more details, refer to TN1279, [MachXO3 Programming and Configuration Usage Guide](#).

The Test Access Port (TAP) has five dual purpose pins (TDI, TDO, TMS, TCK and JTAGENB). These pins are dual function pins - TDI, TDO, TMS and TCK can be used as general purpose I/O if desired. For more details, refer to TN1279, [MachXO3 Programming and Configuration Usage Guide](#).

TransFR (Transparent Field Reconfiguration)

TransFR is a unique Lattice technology that allows users to update their logic in the field without interrupting system operation using a simple push-button solution. For more details refer to TN1087, [Minimizing System Interruption During Configuration Using TransFR Technology](#) for details.

Static Supply Current – C/E Devices^{1, 2, 3, 6}

Symbol	Parameter	Device	Typ. ⁴	Units
I _{CC}	Core Power Supply	LCMXO3L/LF-1300C 256 Ball Package	4.8	mA
		LCMXO3L/LF-2100C	4.8	mA
		LCMXO3L/LF-2100C 324 Ball Package	8.45	mA
		LCMXO3L/LF-4300C	8.45	mA
		LCMXO3L/LF-4300C 400 Ball Package	12.87	mA
		LCMXO3L/LF-6900C ⁷	12.87	mA
		LCMXO3L/LF-9400C ⁷	17.86	mA
		LCMXO3L/LF-640E	1.00	mA
		LCMXO3L/LF-1300E	1.00	mA
		LCMXO3L/LF-1300E 256 Ball Package	1.39	mA
		LCMXO3L/LF-2100E	1.39	mA
		LCMXO3L/LF-2100E 324 Ball Package	2.55	mA
		LCMXO3L/LF-4300E	2.55	mA
		LCMXO3L/LF-6900E	4.06	mA
LCMXO3L/LF-9400E	5.66	mA		
I _{CCIO}	Bank Power Supply ⁵ V _{CCIO} = 2.5 V	All devices	0	mA

1. For further information on supply current, please refer to TN1289, [Power Estimation and Management for MachXO3 Devices](#).
2. Assumes blank pattern with the following characteristics: all outputs are tri-stated, all inputs are configured as LVCMOS and held at V_{CCIO} or GND, on-chip oscillator is off, on-chip PLL is off.
3. Frequency = 0 MHz.
4. T_J = 25 °C, power supplies at nominal voltage.
5. Does not include pull-up/pull-down.
6. To determine the MachXO3L/LF peak start-up current data, use the Power Calculator tool.
7. Determination of safe ambient operating conditions requires use of the Diamond Power Calculator tool.

LVDS Emulation

MachXO3L/LF devices can support LVDS outputs via emulation (LVDS25E). The output is emulated using complementary LVC MOS outputs in conjunction with resistors across the driver outputs on all devices. The scheme shown in Figure 3-1 is one possible solution for LVDS standard implementation. Resistor values in Figure 3-1 are industry standard values for 1% resistors.

Figure 3-1. LVDS Using External Resistors (LVDS25E)

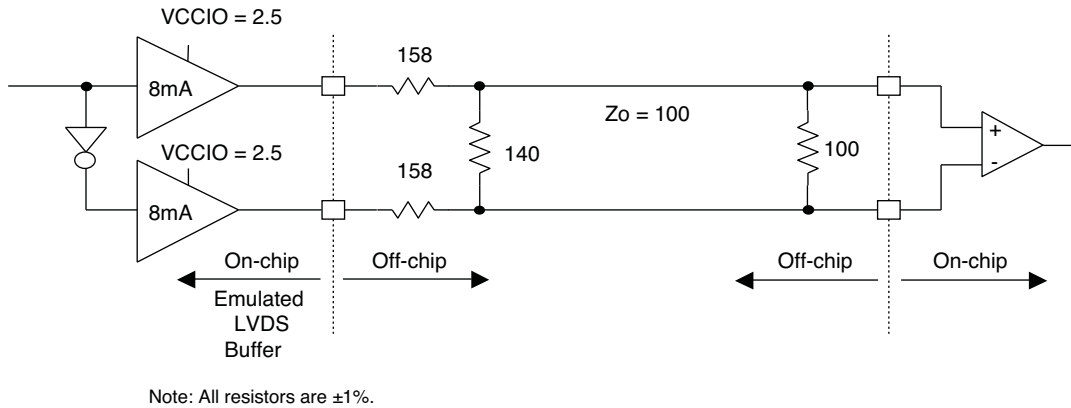

Table 3-1. LVDS25E DC Conditions

Over Recommended Operating Conditions

Parameter	Description	Typ.	Units
Z_{OUT}	Output impedance	20	Ohms
R_S	Driver series resistor	158	Ohms
R_P	Driver parallel resistor	140	Ohms
R_T	Receiver termination	100	Ohms
V_{OH}	Output high voltage	1.43	V
V_{OL}	Output low voltage	1.07	V
V_{OD}	Output differential voltage	0.35	V
V_{CM}	Output common mode voltage	1.25	V
Z_{BACK}	Back impedance	100.5	Ohms
I_{DC}	DC output current	6.03	mA

LVPECL

The MachXO3L/LF family supports the differential LVPECL standard through emulation. This output standard is emulated using complementary LVCMOS outputs in conjunction with resistors across the driver outputs on all the devices. The LVPECL input standard is supported by the LVDS differential input buffer. The scheme shown in Differential LVPECL is one possible solution for point-to-point signals.

Figure 3-3. Differential LVPECL

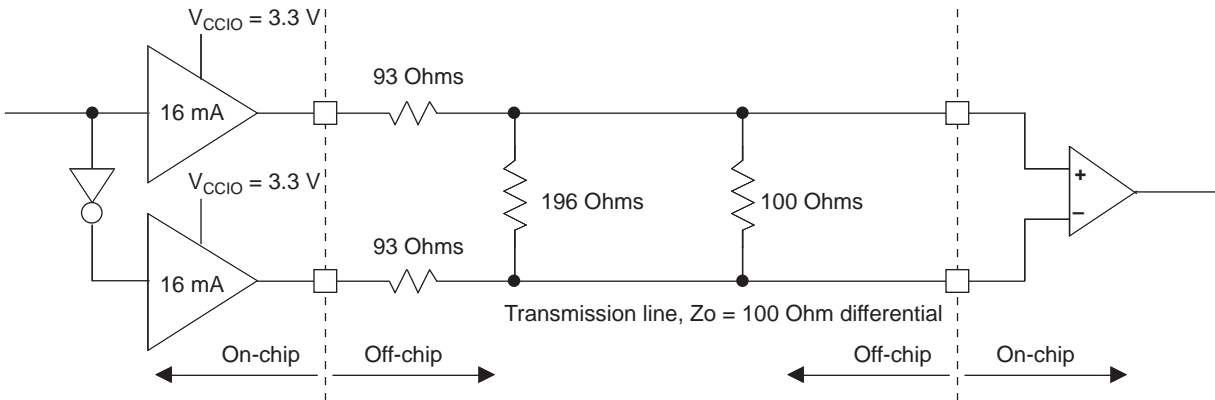

Table 3-3. LVPECL DC Conditions¹

Over Recommended Operating Conditions

Symbol	Description	Nominal	Units
Z_{OUT}	Output impedance	20	Ohms
R_S	Driver series resistor	93	Ohms
R_P	Driver parallel resistor	196	Ohms
R_T	Receiver termination	100	Ohms
V_{OH}	Output high voltage	2.05	V
V_{OL}	Output low voltage	1.25	V
V_{OD}	Output differential voltage	0.80	V
V_{CM}	Output common mode voltage	1.65	V
Z_{BACK}	Back impedance	100.5	Ohms
I_{DC}	DC output current	12.11	mA

1. For input buffer, see LVDS table.

For further information on LVPECL, BLVDS and other differential interfaces please see details of additional technical documentation at the end of the data sheet.

Typical Building Block Function Performance – C/E Devices¹

Pin-to-Pin Performance (LVCMOS25 12 mA Drive)

Function	-6 Timing	Units
Basic Functions		
16-bit decoder	8.9	ns
4:1 MUX	7.5	ns
16:1 MUX	8.3	ns

Register-to-Register Performance

Function	-6 Timing	Units
Basic Functions		
16:1 MUX	412	MHz
16-bit adder	297	MHz
16-bit counter	324	MHz
64-bit counter	161	MHz
Embedded Memory Functions		
1024x9 True-Dual Port RAM (Write Through or Normal, EBR output registers)	183	MHz
Distributed Memory Functions		
16x4 Pseudo-Dual Port RAM (one PFU)	500	MHz

1. The above timing numbers are generated using the Diamond design tool. Exact performance may vary with device and tool version. The tool uses internal parameters that have been characterized but are not tested on every device. Commercial timing numbers are shown at 85 °C and 1.14 V. Other operating conditions, including industrial, can be extracted from the Diamond software.

Derating Logic Timing

Logic timing provided in the following sections of the data sheet and the Lattice design tools are worst case numbers in the operating range. Actual delays may be much faster. Lattice design tools can provide logic timing numbers at a particular temperature and voltage.

Parameter	Description	Device	-6		-5		Units
			Min.	Max.	Min.	Max.	
General I/O Pin Parameters (Using Edge Clock without PLL)							
t _{COE}	Clock to Output - PIO Output Register	MachXO3L/LF-1300	—	7.53	—	7.76	ns
		MachXO3L/LF-2100	—	7.53	—	7.76	ns
		MachXO3L/LF-4300	—	7.45	—	7.68	ns
		MachXO3L/LF-6900	—	7.53	—	7.76	ns
		MachXO3L/LF-9400	—	8.93	—	9.35	ns
t _{SUE}	Clock to Data Setup - PIO Input Register	MachXO3L/LF-1300	-0.19	—	-0.19	—	ns
		MachXO3L/LF-2100	-0.19	—	-0.19	—	ns
		MachXO3L/LF-4300	-0.16	—	-0.16	—	ns
		MachXO3L/LF-6900	-0.19	—	-0.19	—	ns
		MachXO3L/LF-9400	-0.20	—	-0.20	—	ns
t _{HE}	Clock to Data Hold - PIO Input Register	MachXO3L/LF-1300	1.97	—	2.24	—	ns
		MachXO3L/LF-2100	1.97	—	2.24	—	ns
		MachXO3L/LF-4300	1.89	—	2.16	—	ns
		MachXO3L/LF-6900	1.97	—	2.24	—	ns
		MachXO3L/LF-9400	1.98	—	2.25	—	ns
t _{SU_DELE}	Clock to Data Setup - PIO Input Register with Data Input Delay	MachXO3L/LF-1300	1.56	—	1.69	—	ns
		MachXO3L/LF-2100	1.56	—	1.69	—	ns
		MachXO3L/LF-4300	1.74	—	1.88	—	ns
		MachXO3L/LF-6900	1.66	—	1.81	—	ns
		MachXO3L/LF-9400	1.71	—	1.85	—	ns
t _{H_DELE}	Clock to Data Hold - PIO Input Register with Input Data Delay	MachXO3L/LF-1300	-0.23	—	-0.23	—	ns
		MachXO3L/LF-2100	-0.23	—	-0.23	—	ns
		MachXO3L/LF-4300	-0.34	—	-0.34	—	ns
		MachXO3L/LF-6900	-0.29	—	-0.29	—	ns
		MachXO3L/LF-9400	-0.30	—	-0.30	—	ns
General I/O Pin Parameters (Using Primary Clock with PLL)							
t _{COPLL}	Clock to Output - PIO Output Register	MachXO3L/LF-1300	—	5.98	—	6.01	ns
		MachXO3L/LF-2100	—	5.98	—	6.01	ns
		MachXO3L/LF-4300	—	5.99	—	6.02	ns
		MachXO3L/LF-6900	—	6.02	—	6.06	ns
		MachXO3L/LF-9400	—	5.55	—	6.13	ns
t _{SUPLL}	Clock to Data Setup - PIO Input Register	MachXO3L/LF-1300	0.36	—	0.36	—	ns
		MachXO3L/LF-2100	0.36	—	0.36	—	ns
		MachXO3L/LF-4300	0.35	—	0.35	—	ns
		MachXO3L/LF-6900	0.34	—	0.34	—	ns
		MachXO3L/LF-9400	0.33	—	0.33	—	ns
t _{HPLL}	Clock to Data Hold - PIO Input Register	MachXO3L/LF-1300	0.42	—	0.49	—	ns
		MachXO3L/LF-2100	0.42	—	0.49	—	ns
		MachXO3L/LF-4300	0.43	—	0.50	—	ns
		MachXO3L/LF-6900	0.46	—	0.54	—	ns
		MachXO3L/LF-9400	0.47	—	0.55	—	ns

Parameter	Description	Device	-6		-5		Units
			Min.	Max.	Min.	Max.	
MIPI D-PHY Inputs with Clock and Data Centered at Pin Using PCLK Pin for Clock Input - GDDR4_RX.ECLK.Centered^{10, 11, 12}							
t_{SU}^{15}	Input Data Setup Before ECLK	All MachXO3L/LF devices, bottom side only	0.200	—	0.200	—	UI
t_{HO}^{15}	Input Data Hold After ECLK		0.200	—	0.200	—	UI
f_{DATA}^{14}	MIPI D-PHY Input Data Speed		—	900	—	900	Mbps
f_{DDR4}^{14}	MIPI D-PHY ECLK Frequency		—	450	—	450	MHz
f_{SCLK}^{14}	SCLK Frequency		—	112.5	—	112.5	MHz
Generic DDR Outputs with Clock and Data Aligned at Pin Using PCLK Pin for Clock Input – GDDR1_TX.SCLK.Aligned⁸							
t_{DIA}	Output Data Invalid After CLK Output	All MachXO3L/LF devices, all sides	—	0.520	—	0.550	ns
t_{DIB}	Output Data Invalid Before CLK Output		—	0.520	—	0.550	ns
f_{DATA}	DDR1 Output Data Speed		—	300	—	250	Mbps
f_{DDR1}	DDR1 SCLK frequency		—	150	—	125	MHz
Generic DDR Outputs with Clock and Data Centered at Pin Using PCLK Pin for Clock Input – GDDR1_TX.SCLK.Centered⁸							
t_{DVB}	Output Data Valid Before CLK Output	All MachXO3L/LF devices, all sides	1.210	—	1.510	—	ns
t_{DVA}	Output Data Valid After CLK Output		1.210	—	1.510	—	ns
f_{DATA}	DDR1 Output Data Speed		—	300	—	250	Mbps
f_{DDR1}	DDR1 SCLK Frequency (minimum limited by PLL)		—	150	—	125	MHz
Generic DDR2 Outputs with Clock and Data Aligned at Pin Using PCLK Pin for Clock Input – GDDR2_TX.ECLK.Aligned⁸							
t_{DIA}	Output Data Invalid After CLK Output	MachXO3L/LF devices, top side only	—	0.200	—	0.215	ns
t_{DIB}	Output Data Invalid Before CLK Output		—	0.200	—	0.215	ns
f_{DATA}	DDR2 Serial Output Data Speed		—	664	—	554	Mbps
f_{DDR2}	DDR2 ECLK frequency		—	332	—	277	MHz
f_{SCLK}	SCLK Frequency		—	166	—	139	MHz
Generic DDR2 Outputs with Clock and Data Centered at Pin Using PCLK Pin for Clock Input – GDDR2_TX.ECLK.Centered^{8, 9}							
t_{DVB}	Output Data Valid Before CLK Output	MachXO3L/LF devices, top side only	0.535	—	0.670	—	ns
t_{DVA}	Output Data Valid After CLK Output		0.535	—	0.670	—	ns
f_{DATA}	DDR2 Serial Output Data Speed		—	664	—	554	Mbps
f_{DDR2}	DDR2 ECLK Frequency (minimum limited by PLL)		—	332	—	277	MHz
f_{SCLK}	SCLK Frequency		—	166	—	139	MHz
Generic DDR4 Outputs with Clock and Data Aligned at Pin Using PCLK Pin for Clock Input – GDDR4_TX.ECLK.Aligned^{8, 9}							
t_{DIA}	Output Data Invalid After CLK Output	MachXO3L/LF devices, top side only	—	0.200	—	0.215	ns
t_{DIB}	Output Data Invalid Before CLK Output		—	0.200	—	0.215	ns
f_{DATA}	DDR4 Serial Output Data Speed		—	800	—	630	Mbps
f_{DDR4}	DDR4 ECLK Frequency		—	400	—	315	MHz
f_{SCLK}	SCLK Frequency		—	100	—	79	MHz

NVCM/Flash Download Time^{1, 2}

Symbol	Parameter	Device	Typ.	Units
t _{REFRESH}	POR to Device I/O Active	LCMXO3L/LF-640	1.9	ms
		LCMXO3L/LF-1300	1.9	ms
		LCMXO3L/LF-1300 256-Ball Package	1.4	ms
		LCMXO3L/LF-2100	1.4	ms
		LCMXO3L/LF-2100 324-Ball Package	2.4	ms
		LCMXO3L/LF-4300	2.4	ms
		LCMXO3L/LF-4300 400-Ball Package	3.8	ms
		LCMXO3L/LF-6900	3.8	ms
		LCMXO3L/LF-9400C	5.2	ms

1. Assumes sysMEM EBR initialized to an all zero pattern if they are used.

2. The NVCM/Flash download time is measured starting from the maximum voltage of POR trip point.

Signal Descriptions (Cont.)

Signal Name	I/O	Descriptions
Configuration (Dual function pins used during sysCONFIG)		
PROGRAMN	I	Initiates configuration sequence when asserted low. This pin always has an active pull-up.
INITN	I/O	Open Drain pin. Indicates the FPGA is ready to be configured. During configuration, a pull-up is enabled.
DONE	I/O	Open Drain pin. Indicates that the configuration sequence is complete, and the start-up sequence is in progress.
MCLK/CCLK	I/O	Input Configuration Clock for configuring an FPGA in Slave SPI mode. Output Configuration Clock for configuring an FPGA in SPI and SPIm configuration modes.
SN	I	Slave SPI active low chip select input.
CSSPIN	I/O	Master SPI active low chip select output.
SI/SPISI	I/O	Slave SPI serial data input and master SPI serial data output.
SO/SPISO	I/O	Slave SPI serial data output and master SPI serial data input.
SCL	I/O	Slave I ² C clock input and master I ² C clock output.
SDA	I/O	Slave I ² C data input and master I ² C data output.

MachXO3 Part Number Description

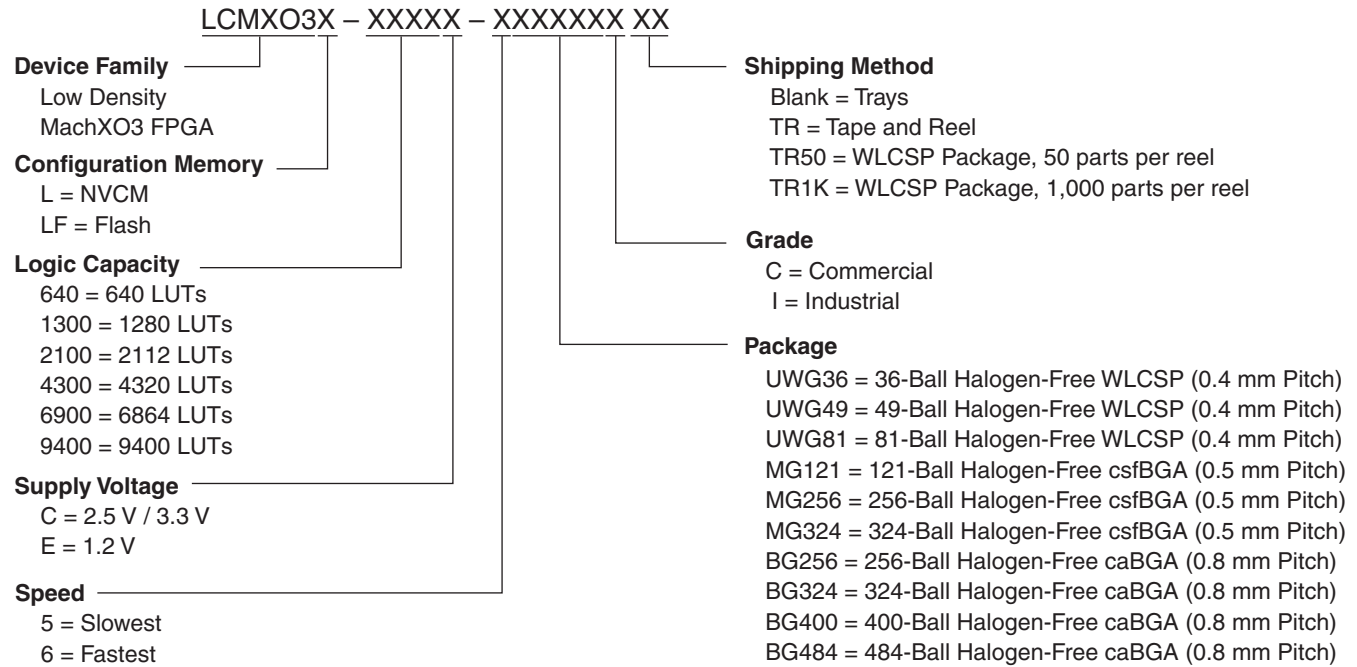

Ordering Information

MachXO3L/LF devices have top-side markings as shown in the examples below, on the 256-Ball caBGA package with MachXO3-6900 device in Commercial Temperature in Speed Grade 5. Notice that for the MachXO3LF device, *LMXO3LF* is used instead of *LCMXO3LF* as in the Part Number.



Note: *LCMXO3LF* is marked with *LMXO3LF*

Note: Markings are abbreviated for small packages.

Part Number	LUTs	Supply Voltage	Speed	Package	Leads	Temp.
LCMXO3L-2100E-6MG324I	2100	1.2 V	6	Halogen-Free csfBGA	324	IND
LCMXO3L-2100C-5BG256C	2100	2.5 V / 3.3 V	5	Halogen-Free caBGA	256	COM
LCMXO3L-2100C-6BG256C	2100	2.5 V / 3.3 V	6	Halogen-Free caBGA	256	COM
LCMXO3L-2100C-5BG256I	2100	2.5 V / 3.3 V	5	Halogen-Free caBGA	256	IND
LCMXO3L-2100C-6BG256I	2100	2.5 V / 3.3 V	6	Halogen-Free caBGA	256	IND
LCMXO3L-2100C-5BG324C	2100	2.5 V / 3.3 V	5	Halogen-Free caBGA	324	COM
LCMXO3L-2100C-6BG324C	2100	2.5 V / 3.3 V	6	Halogen-Free caBGA	324	COM
LCMXO3L-2100C-5BG324I	2100	2.5 V / 3.3 V	5	Halogen-Free caBGA	324	IND
LCMXO3L-2100C-6BG324I	2100	2.5 V / 3.3 V	6	Halogen-Free caBGA	324	IND

Part Number	LUTs	Supply Voltage	Speed	Package	Leads	Temp.
LCMXO3L-4300E-5UWG81CTR	4300	1.2 V	5	Halogen-Free WLCSP	81	COM
LCMXO3L-4300E-5UWG81CTR50	4300	1.2 V	5	Halogen-Free WLCSP	81	COM
LCMXO3L-4300E-5UWG81CTR1K	4300	1.2 V	5	Halogen-Free WLCSP	81	COM
LCMXO3L-4300E-5UWG81ITR	4300	1.2 V	5	Halogen-Free WLCSP	81	IND
LCMXO3L-4300E-5UWG81ITR50	4300	1.2 V	5	Halogen-Free WLCSP	81	IND
LCMXO3L-4300E-5UWG81ITR1K	4300	1.2 V	5	Halogen-Free WLCSP	81	IND
LCMXO3L-4300E-5MG121C	4300	1.2 V	5	Halogen-Free csfBGA	121	COM
LCMXO3L-4300E-6MG121C	4300	1.2 V	6	Halogen-Free csfBGA	121	COM
LCMXO3L-4300E-5MG121I	4300	1.2 V	5	Halogen-Free csfBGA	121	IND
LCMXO3L-4300E-6MG121I	4300	1.2 V	6	Halogen-Free csfBGA	121	IND
LCMXO3L-4300E-5MG256C	4300	1.2 V	5	Halogen-Free csfBGA	256	COM
LCMXO3L-4300E-6MG256C	4300	1.2 V	6	Halogen-Free csfBGA	256	COM
LCMXO3L-4300E-5MG256I	4300	1.2 V	5	Halogen-Free csfBGA	256	IND
LCMXO3L-4300E-6MG256I	4300	1.2 V	6	Halogen-Free csfBGA	256	IND
LCMXO3L-4300E-5MG324C	4300	1.2 V	5	Halogen-Free csfBGA	324	COM
LCMXO3L-4300E-6MG324C	4300	1.2 V	6	Halogen-Free csfBGA	324	COM
LCMXO3L-4300E-5MG324I	4300	1.2 V	5	Halogen-Free csfBGA	324	IND
LCMXO3L-4300E-6MG324I	4300	1.2 V	6	Halogen-Free csfBGA	324	IND
LCMXO3L-4300C-5BG256C	4300	2.5 V / 3.3 V	5	Halogen-Free caBGA	256	COM
LCMXO3L-4300C-6BG256C	4300	2.5 V / 3.3 V	6	Halogen-Free caBGA	256	COM
LCMXO3L-4300C-5BG256I	4300	2.5 V / 3.3 V	5	Halogen-Free caBGA	256	IND
LCMXO3L-4300C-6BG256I	4300	2.5 V / 3.3 V	6	Halogen-Free caBGA	256	IND
LCMXO3L-4300C-5BG324C	4300	2.5 V / 3.3 V	5	Halogen-Free caBGA	324	COM
LCMXO3L-4300C-6BG324C	4300	2.5 V / 3.3 V	6	Halogen-Free caBGA	324	COM
LCMXO3L-4300C-5BG324I	4300	2.5 V / 3.3 V	5	Halogen-Free caBGA	324	IND
LCMXO3L-4300C-6BG324I	4300	2.5 V / 3.3 V	6	Halogen-Free caBGA	324	IND
LCMXO3L-4300C-5BG400C	4300	2.5 V / 3.3 V	5	Halogen-Free caBGA	400	COM
LCMXO3L-4300C-6BG400C	4300	2.5 V / 3.3 V	6	Halogen-Free caBGA	400	COM
LCMXO3L-4300C-5BG400I	4300	2.5 V / 3.3 V	5	Halogen-Free caBGA	400	IND
LCMXO3L-4300C-6BG400I	4300	2.5 V / 3.3 V	6	Halogen-Free caBGA	400	IND

Part Number	LUTs	Supply Voltage	Speed	Package	Leads	Temp.
LCMXO3L-6900E-5MG256C	6900	1.2 V	5	Halogen-Free csfBGA	256	COM
LCMXO3L-6900E-6MG256C	6900	1.2 V	6	Halogen-Free csfBGA	256	COM
LCMXO3L-6900E-5MG256I	6900	1.2 V	5	Halogen-Free csfBGA	256	IND
LCMXO3L-6900E-6MG256I	6900	1.2 V	6	Halogen-Free csfBGA	256	IND
LCMXO3L-6900E-5MG324C	6900	1.2 V	5	Halogen-Free csfBGA	324	COM
LCMXO3L-6900E-6MG324C	6900	1.2 V	6	Halogen-Free csfBGA	324	COM
LCMXO3L-6900E-5MG324I	6900	1.2 V	5	Halogen-Free csfBGA	324	IND
LCMXO3L-6900E-6MG324I	6900	1.2 V	6	Halogen-Free csfBGA	324	IND
LCMXO3L-6900C-5BG256C	6900	2.5 V / 3.3 V	5	Halogen-Free caBGA	256	COM
LCMXO3L-6900C-6BG256C	6900	2.5 V / 3.3 V	6	Halogen-Free caBGA	256	COM
LCMXO3L-6900C-5BG256I	6900	2.5 V / 3.3 V	5	Halogen-Free caBGA	256	IND
LCMXO3L-6900C-6BG256I	6900	2.5 V / 3.3 V	6	Halogen-Free caBGA	256	IND
LCMXO3L-6900C-5BG324C	6900	2.5 V / 3.3 V	5	Halogen-Free caBGA	324	COM
LCMXO3L-6900C-6BG324C	6900	2.5 V / 3.3 V	6	Halogen-Free caBGA	324	COM
LCMXO3L-6900C-5BG324I	6900	2.5 V / 3.3 V	5	Halogen-Free caBGA	324	IND
LCMXO3L-6900C-6BG324I	6900	2.5 V / 3.3 V	6	Halogen-Free caBGA	324	IND
LCMXO3L-6900C-5BG400C	6900	2.5 V / 3.3 V	5	Halogen-Free caBGA	400	COM
LCMXO3L-6900C-6BG400C	6900	2.5 V / 3.3 V	6	Halogen-Free caBGA	400	COM
LCMXO3L-6900C-5BG400I	6900	2.5 V / 3.3 V	5	Halogen-Free caBGA	400	IND
LCMXO3L-6900C-6BG400I	6900	2.5 V / 3.3 V	6	Halogen-Free caBGA	400	IND

Part Number	LUTs	Supply Voltage	Speed	Package	Leads	Temp.
LCMXO3L-9400E-5MG256C	9400	1.2 V	5	Halogen-Free csfBGA	256	COM
LCMXO3L-9400E-6MG256C	9400	1.2 V	6	Halogen-Free csfBGA	256	COM
LCMXO3L-9400E-5MG256I	9400	1.2 V	5	Halogen-Free csfBGA	256	IND
LCMXO3L-9400E-6MG256I	9400	1.2 V	6	Halogen-Free csfBGA	256	IND
LCMXO3L-9400C-5BG256C	9400	2.5 V/3.3 V	5	Halogen-Free caBGA	256	COM
LCMXO3L-9400C-6BG256C	9400	2.5 V/3.3 V	6	Halogen-Free caBGA	256	COM
LCMXO3L-9400C-5BG256I	9400	2.5 V/3.3 V	5	Halogen-Free caBGA	256	IND
LCMXO3L-9400C-6BG256I	9400	2.5 V/3.3 V	6	Halogen-Free caBGA	256	IND
LCMXO3L-9400C-5BG400C	9400	2.5 V/3.3 V	5	Halogen-Free caBGA	400	COM
LCMXO3L-9400C-6BG400C	9400	2.5 V/3.3 V	6	Halogen-Free caBGA	400	COM
LCMXO3L-9400C-5BG400I	9400	2.5 V/3.3 V	5	Halogen-Free caBGA	400	IND
LCMXO3L-9400C-6BG400I	9400	2.5 V/3.3 V	6	Halogen-Free caBGA	400	IND
LCMXO3L-9400C-5BG484C	9400	2.5 V/3.3 V	5	Halogen-Free caBGA	484	COM
LCMXO3L-9400C-6BG484C	9400	2.5 V/3.3 V	6	Halogen-Free caBGA	484	COM
LCMXO3L-9400C-5BG484I	9400	2.5 V/3.3 V	5	Halogen-Free caBGA	484	IND
LCMXO3L-9400C-6BG484I	9400	2.5 V/3.3 V	6	Halogen-Free caBGA	484	IND

Date	Version	Section	Change Summary
February 2017	1.8	Architecture	Updated Supported Standards section. Corrected “MDVS” to “MLDVS” in Table 2-11, Supported Input Standards.
		DC and Switching Characteristics	Updated ESD Performance section. Added reference to the MachXO2 Product Family Qualification Summary document.
			Updated Static Supply Current – C/E Devices section. Added footnote 7.
			Updated MachXO3L/LF External Switching Characteristics – C/E Devices section. — Populated values for MachXO3L/LF-9400. — Under 7:1 LVDS Outputs – GDDR71_TX.ECLK.7:1, corrected “t _{DVB} ” to “t _{DIB} ” and “t _{DVA} ” to “t _{DIA} ” and revised their descriptions. — Added Figure 3-6, Receiver GDDR71_RX Waveforms and Figure 3-7, Transmitter GDDR71_TX Waveforms.
Pinout Information	Updated the Pin Information Summary section. Added MachXO3L/LF-9600C packages.		
May 2016	1.7	DC and Switching Characteristics	Updated Absolute Maximum Ratings section. Modified I/O Tri-state Voltage Applied and Dedicated Input Voltage Applied footnotes.
			Updated sysIO Recommended Operating Conditions section. — Added standards. — Added V _{REF} (V) — Added footnote 4.
			Updated sysIO Single-Ended DC Electrical Characteristics section. Added I/O standards.
		Ordering Information	Updated MachXO3L Ultra Low Power Commercial and Industrial Grade Devices, Halogen Free (RoHS) Packaging section. Added LCMXO3L-9400C part numbers.
Updated MachXO3LF Ultra Low Power Commercial and Industrial Grade Devices, Halogen Free (RoHS) Packaging section. Added LCMXO3L-9400C part numbers.			