

Welcome to [E-XFL.COM](https://www.e-xfl.com)

Embedded - Microcontrollers - Application Specific: Tailored Solutions for Precision and Performance

Embedded - Microcontrollers - Application Specific represents a category of microcontrollers designed with unique features and capabilities tailored to specific application needs. Unlike general-purpose microcontrollers, application-specific microcontrollers are optimized for particular tasks, offering enhanced performance, efficiency, and functionality to meet the demands of specialized applications.

What Are Embedded - Microcontrollers - Application Specific?

Application specific microcontrollers are engineered to

Details

Product Status	Active
Applications	Inductive Sensor Interface
Core Processor	32-Bit RISC
Program Memory Type	ROM (12kB)
Controller Series	-
RAM Size	-
Interface	Analog, PWM
Number of I/O	-
Voltage - Supply	-
Operating Temperature	-40°C ~ 150°C
Mounting Type	Surface Mount
Package / Case	14-TSSOP (0.173", 4.40mm Width)
Supplier Device Package	14-TSSOP
Purchase URL	https://www.e-xfl.com/product-detail/microchip-technology/lx3302aqpw-tr

LX3302

Key Features

- Embedded 32-bit processing engine with 12 KB program memory
- Two sensor input channels with integrated demodulator
- Internal oscillator with frequency range of 1 to 5 MHz
- Dual 13-bit ADC with sample rates to 2kHz
- User-programmable 32 x 16-bit non-volatile configuration memory
- Linearization algorithm with:
 - Eight user-defined linearization points
 - Programmable origin and end points
 - Programmable low and high plateau levels
- Multiple diagnostics features (ISO26262 compliant)
- Host interface: analog , PWM, PSI5, and SENT (J2716 JAN2010)
- 8kV ESD protection (HBM) on power, ground, Mux-Pins
- 4.5V to 5.6V input voltage; 10mA (typical) operating current
- -40 to 150 °C operation, AEC-Q100 grade 0 certified

Description

The LX3302 is the second member of Microsemi’s new family of smart sensor interface products. Designed to process inductive sensors which are based upon linear variable differential transformer (LVDT) principles, this new device integrates two complete analog channels, oscillator/exciter, 32-bit RISC processor, non-volatile configuration memory, and four programmable I/O which support a variety of interface options. In addition, the LX3302 provides internal 8kV (HBM) ESD protection on the power, ground, and system interface pins, eliminating the need for external protection components.

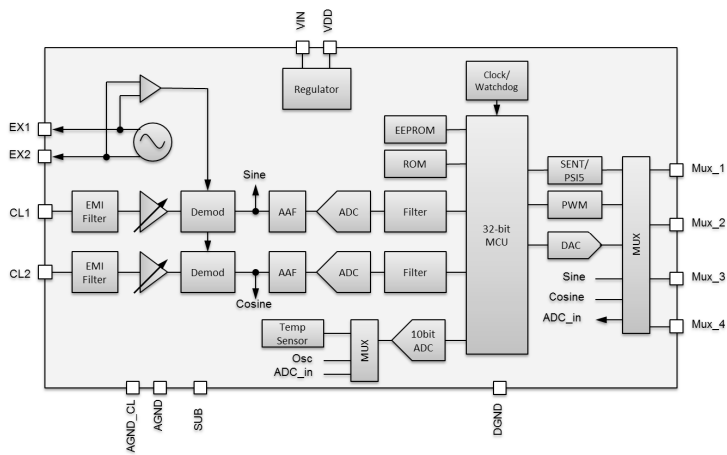

Figure 1: Top-level Block Diagram

In typical operation, inputs from the inductive sensor are conditioned, demodulated, and converted into 13-bit values. The MCU processes these values to produce a linearized measurement value with either 12-bit accuracy (analog, PSI5, or SENT output) or 13-bit accuracy (PWM output.) Internal non-volatile memory allows the user to configure various parameters within the IC, including eight calibration points, origin/end points, and low and high plateau levels.

The internal non-volatile memory is configured via the VIN power pin, which allows a sensor assembly to be configured without the need for additional programming pins.

In addition to the traditional analog and PWM outputs, the LX3302 includes a fully compliant Single Edge Nibble Transmission (SENT) interface and a Peripheral Serial Interface (PSI5) interface to support next generation automotive controllers.

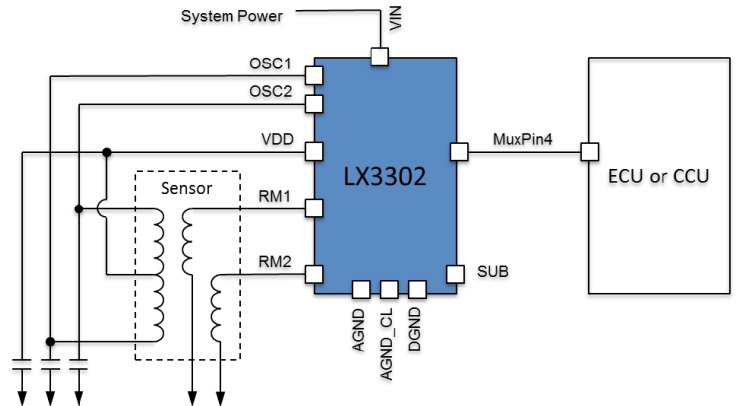

Figure 2: LVDT/Inductive Sensor Configuration

The LX3302 includes integrated diagnostics features which regularly monitor various functions within the IC and report conditions which are outside of specified parameters. In the event of a detected failure, the device drives the output to a pre-defined diagnostics level. The internal diagnostics information can also be output via SENT-compatible protocol for system development and debug purposes.

The LX3302 is compliant with ISO26262 and rated for ASIL C applications. Packaged in a 14-TSSOP package, the device is designed for harsh environments supporting operation (to specification) from -40 to 150 °C while maintaining full functionality to 175 °C. The LX3302 is certified to AEC-Q100 grade 0.

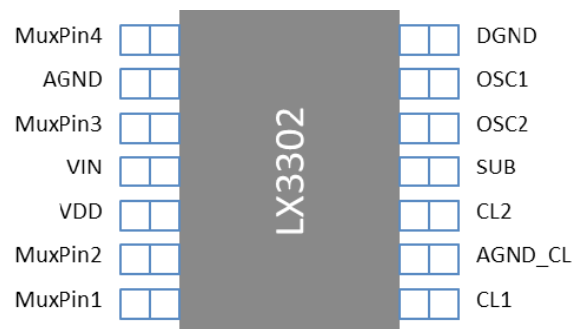

Figure 3: 14-TSSOP Pin Assignments

LX3302

Target Applications

The LX3302 is an ideal solution for measuring mechanical movement (linear, angular/rotation and proximity) in a wide variety of applications in automotive, industrial, aerospace, and commercial applications including:

- Rotor position sensing (brushless DC motors)
- Robotic arm positioning
- Fluid level sensing
- Proximity detection (industrial automation)
- Gear position/travel (automotive)

Microsemi makes no warranty, representation, or guarantee regarding the information contained herein or the suitability of its products and services for any particular purpose, nor does Microsemi assume any liability whatsoever arising out of the application or use of any product or circuit. The products sold hereunder and any other products sold by Microsemi have been subject to limited testing and should not be used in conjunction with mission-critical equipment or applications. Any performance specifications are believed to be reliable but are not verified, and Buyer must conduct and complete all performance and other testing of the products, alone and together with, or installed in, any end-products. Buyer shall not rely on any data and performance specifications or parameters provided by Microsemi. It is the Buyer's responsibility to independently determine suitability of any products and to test and verify the same. The information provided by Microsemi hereunder is provided "as is, where is" and with all faults, and the entire risk associated with such information is entirely with the Buyer. Microsemi does not grant, explicitly or implicitly, to any party any patent rights, licenses, or any other IP rights, whether with regard to such information itself or anything described by such information. Information provided in this document is proprietary to Microsemi, and Microsemi reserves the right to make any changes to the information in this document or to any products and services at any time without notice.



Microsemi

Microsemi Corporate Headquarters
One Enterprise, Aliso Viejo, CA 92656 USA
Within the USA: +1 (800) 713-4113
Outside the USA: +1 (949) 380-6100
Sales: +1 (949) 380-6136
Fax: +1 (949) 215-4996
email: sales.support@microsemi.com
www.microsemi.com

Microsemi Corporation (Nasdaq: MSCC) offers a comprehensive portfolio of semiconductor and system solutions for communications, defense & security, aerospace and industrial markets. Products include high-performance and radiation-hardened analog mixed-signal integrated circuits, FPGAs, SoCs and ASICs; power management products; timing and synchronization devices and precise time solutions, setting the world's standard for time; voice processing devices; RF solutions; discrete components; security technologies and scalable anti-tamper products; Power-over-Ethernet ICs and midspans; as well as custom design capabilities and services. Microsemi is headquartered in Aliso Viejo, Calif., and has approximately 3,400 employees globally. Learn more at www.microsemi.com.

©2015 Microsemi Corporation. All rights reserved. Microsemi and the Microsemi logo are registered trademarks of Microsemi Corporation. All other trademarks and service marks are the property of their respective owners.