

Welcome to [E-XFL.COM](https://www.e-xfl.com)

## Understanding [Embedded - FPGAs \(Field Programmable Gate Array\)](#)

Embedded - FPGAs, or Field Programmable Gate Arrays, are advanced integrated circuits that offer unparalleled flexibility and performance for digital systems. Unlike traditional fixed-function logic devices, FPGAs can be programmed and reprogrammed to execute a wide array of logical operations, enabling customized functionality tailored to specific applications. This reprogrammability allows developers to iterate designs quickly and implement complex functions without the need for custom hardware.

## Applications of Embedded - FPGAs

The versatility of Embedded - FPGAs makes them indispensable in numerous fields. In telecommunications.

### Details

Product Status	Obsolete
Number of LABs/CLBs	20000
Number of Logic Elements/Cells	80000
Total RAM Bits	5816320
Number of I/O	660
Number of Gates	-
Voltage - Supply	0.95V ~ 1.26V
Mounting Type	Surface Mount
Operating Temperature	0°C ~ 85°C (TJ)
Package / Case	1152-BBGA, FCBGA
Supplier Device Package	1152-FCBGA (35x35)
Purchase URL	<a href="https://www.e-xfl.com/product-detail/lattice-semiconductor/lfscm3ga80ep1-5fcn1152c">https://www.e-xfl.com/product-detail/lattice-semiconductor/lfscm3ga80ep1-5fcn1152c</a>

## Architecture Overview

The LatticeSC architecture contains an array of logic blocks surrounded by Programmable I/O Cells (PIC). Interspersed between the rows of logic blocks are rows of sysMEM Embedded Block RAM (EBR). The upper left and upper right corners of the devices contain SERDES blocks and their associated PCS blocks, as shown in Figure 2-1.

Top left and top right corner of the device contain blocks of SERDES. Each block of SERDES contains four channels (quad). Each channel contains a single serializer and de-serializer, synchronization and word alignment logic. The SERDES quad connects with the Physical Coding Sub-layer (PCS) blocks that contain logic to simultaneously perform alignment, coding, de-coding and other functions. The SERDES quad block has separate supply, ground and reference voltage pins.

The PICs contain logic to facilitate the conditioning of signals to and from the I/O before they leave or enter the FPGA fabric. The block provides DDR and shift register capabilities that act as a gearbox between high speed I/O and the FPGA fabric. The blocks also contain programmable Adaptive Input Logic that adjusts the delay applied to signals as they enter the device to optimize setup and hold times and ensure robust performance.

sysMEM EBRs are large dedicated fast memory blocks. They can be configured as RAM, ROM or FIFO. These blocks have dedicated logic to simplify the implementation of FIFOs.

The PFU, PIC and EBR blocks are arranged in a two-dimensional grid with rows and columns as shown in Figure 2-1. These blocks are connected with many vertical and horizontal routing channel resources. The place and route software tool automatically allocates these routing resources.

The corners contain the sysCLOCK Analog Phase Locked Loop (PLL) and Delay Locked Loop (DLL) Blocks. The PLLs have multiply, divide and phase shifting capability; they are used to manage the phase relationship of the clocks. The LatticeSC architecture provides eight analog PLLs per device and 12 DLLs. The DLLs provide a simple delay capability and can also be used to calibrate other delays within the device.

Every device in the family has a JTAG Port with internal Logic Analyzer (ispTRACY) capability. The sysCONFIG™ port which allows for serial or parallel device configuration. The system bus simplifies the connections of the external microprocessor to the device for tasks such as SERDES and PCS configuration or interface to the general FPGA logic. The LatticeSC devices use 1.2V as their core voltage operation with 1.0V operation also possible.

Figure 2-1. Simplified Block Diagram (Top Level)

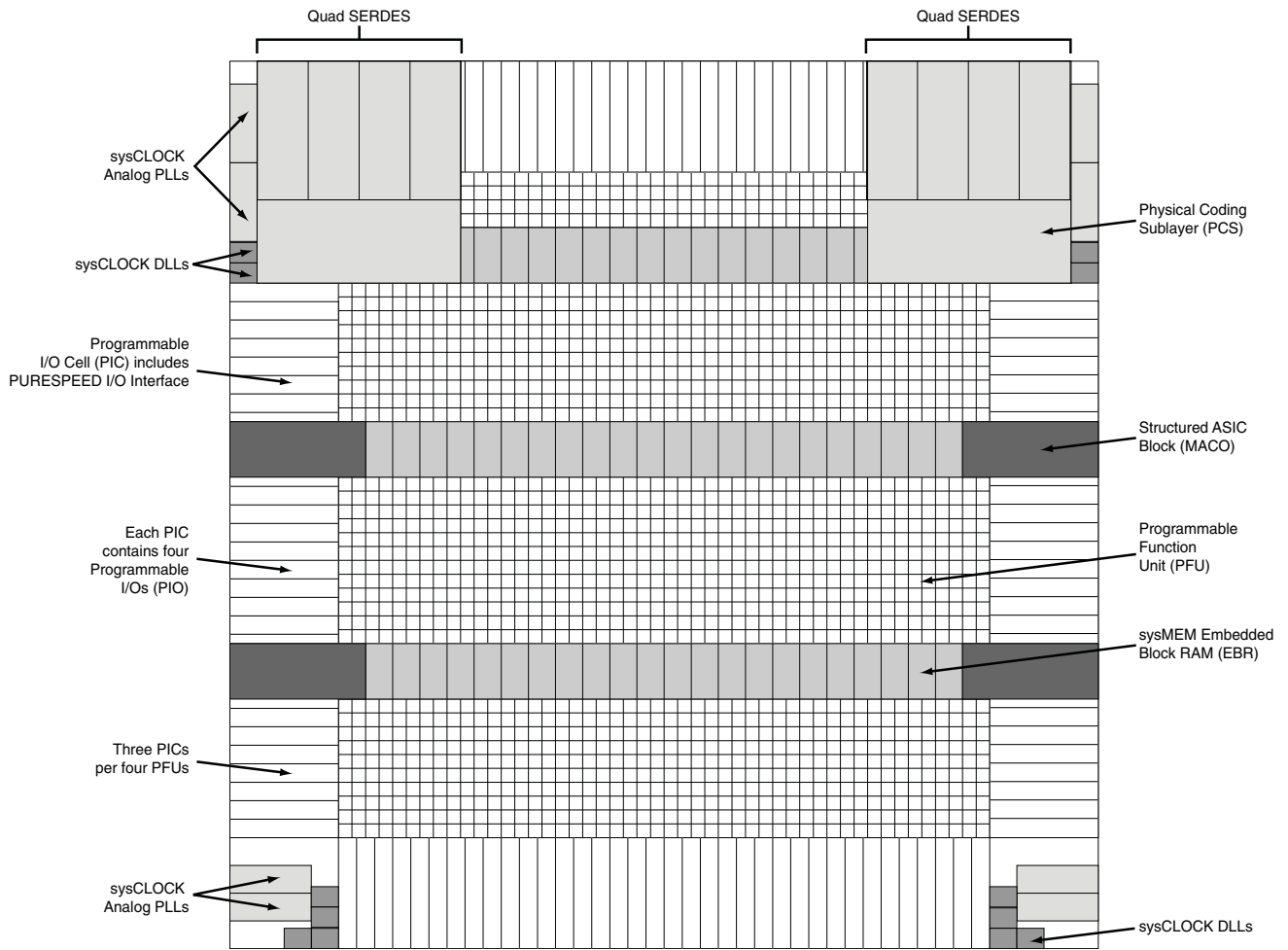

## PFU Modes of Operation

Slices can be combined within a PFU to form larger functions. Table 2-4 tabulates these modes and documents the functionality possible at the PFU level.

**Table 2-4. PFU Modes of Operation**

Logic	Ripple	RAM	ROM
LUT 4x8 or MUX 2x1 x 8	2-bit Add x 4	SPR 16x2 x 4 DPR 16x2 x 2	ROM 16x1 x 8
LUT 5x4 or MUX 4x1 x 4	2-bit Sub x 4	SPR 16x4 x 2 DPR 16x4 x 1	ROM 16x2 x 4
LUT 6x2 or MUX 8x1 x 2	2-bit Counter x 4	SPR 16x8 x 1	ROM 16x4 x 2
LUT 7x1 or MUX 16x1 x 1	2-bit Comp x 4		ROM 16x8 x 1

## Routing

There are many resources provided in the LatticeSC devices to route signals individually or as busses with related control signals. The routing resources consist of switching circuitry, buffers and metal interconnect (routing) segments.

The inter-PFU connections are made with x1 (spans two PFU), x2 (spans three PFU) and x6 (spans seven PFU) resources. The x1 and x2 connections provide fast and efficient connections in horizontal, vertical and diagonal directions. All connections are buffered to ensure high-speed operation even with long high-fanout connections.

The ispLEVER design tool takes the output of the synthesis tool and places and routes the design. Generally, the place and route tool is completely automatic, although an interactive routing editor is available to optimize the design.

## sysCLOCK Network

The LatticeSC devices have three distinct clock networks for use in distributing high-performance clocks within the device: primary clocks, secondary clocks and edge clocks. In addition to these dedicated clock networks, users are free to route clocks within the device using the general purpose routing. Figure 2-4 shows the clock resources available to each slice.

**Figure 2-4. Slice Clock Selection**

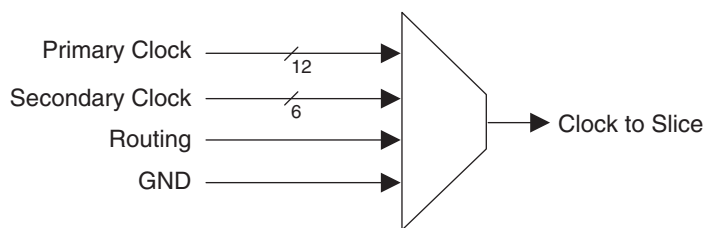

Note: GND is available to switch off the network.

## Primary Clock Sources

LatticeSC devices have a wide variety of primary clock sources available. Primary clocks sources consists of the following:

- Primary clock input pins
- Edge clock input pins
- Two outputs per DLL

Figure 2-32. PowerPCI and MPI Schematic

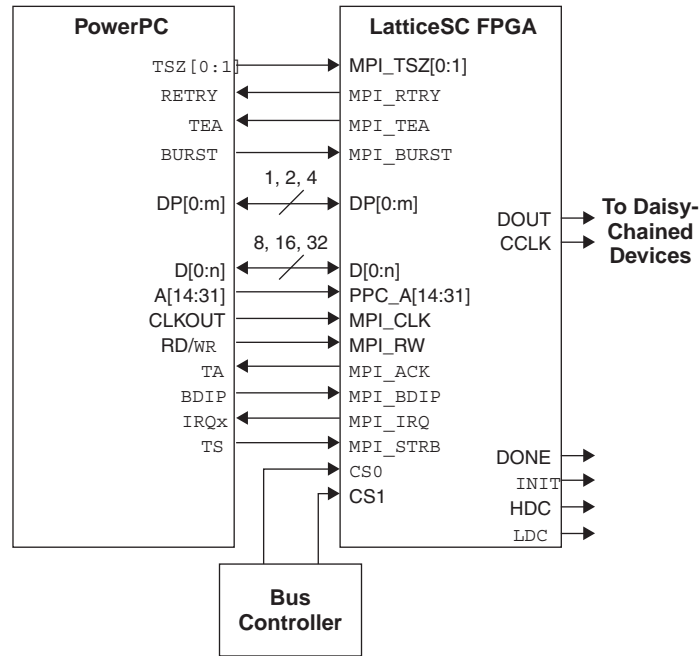

## Configuration and Testing

The following section describes the configuration and testing features of the LatticeSC family of devices.

### IEEE 1149.1-Compliant Boundary Scan Testability

All LatticeSC devices have boundary scan cells that are accessed through an IEEE 1149.1 compliant test access port (TAP). This allows functional testing of the circuit board, on which the device is mounted, through a serial scan path that can access all critical logic nodes. Internal registers are linked internally, allowing test data to be shifted in and loaded directly onto test nodes, or test data to be captured and shifted out for verification. The test access port consists of dedicated I/Os: TDI, TDO, TCK and TMS. The test access port has its own supply voltage  $V_{CCJ}$  and can operate with LVCMOS33, 25 and 18 standards. For additional detail refer to technical information at the end of the data sheet.

### Device Configuration

All LatticeSC devices contain three possible ports that can be used for device configuration. The serial port, which supports bit-wide configuration, and the sysCONFIG port that supports both byte-wide and serial configuration. The MPI port supports 8-bit, 16-bit or 32-bit configuration.

The serial port supports both the IEEE Std. 1149.1 Boundary Scan specification and the IEEE Std. 1532 In-System Configuration specification. The sysCONFIG port is a 20-pin interface with six of the I/Os used as dedicated pins and the rest being dual-use pins. When sysCONFIG mode is not used, these dual-use pins are available for general purpose I/O. All I/Os for the sysCONFIG and MPI ports are in I/O bank #1.

On power-up, the FPGA SRAM is ready to be configured with the sysCONFIG port active. The IEEE 1149.1 serial mode can be activated any time after power-up by sending the appropriate command through the TAP port. Once a configuration port is selected, that port is locked and another configuration port cannot be activated until the next re-initialization sequence. For additional detail refer to technical information at the end of the data sheet.

### Signal Descriptions

Signal Name	I/O	Description
<b>General Purpose</b>		
P[Edge] [Row/Column Number*]_[A/B/C/D]	I/O	<p>[Edge] indicates the edge of the device on which the pad is located. Valid edge designations are L (Left), B (Bottom), R (Right), T (Top).</p> <p>[Row/Column Number] indicates the PIC row or the column of the device on which the PIC exists. When Edge is T (Top) or (Bottom), only need to specify Row Number. When Edge is L (Left) or R (Right), only need to specify Column Number.</p> <p>[A/B/C/D] indicates the PIO within the PIC to which the pad is connected.</p> <p>Some of these user programmable pins are shared with special function pins. These pin when not used as special purpose pins can be programmed as I/Os for user logic.</p> <p>During configuration the user-programmable I/Os are tri-stated with an internal pull-up resistor enabled. If any pin is not used (or not bonded to a package pin), it is also tri-stated with an internal pull-up resistor enabled after configuration.</p>
VREF1_x, VREF2_x	—	The reference supply pins for I/O bank x. Any I/O pin in a bank can be assigned as a reference supply pin, but software defaults use designated pin.
NC	—	No connect. NC pins should not be connected to any active signals, VCC or GND.
<b>Non-SERDES Power Supplies</b>		
VCCIOx	—	VCCIO - The power supply pins for I/O bank x. Dedicated pins.
VCC12 <sup>1</sup>	—	1.2V supply for configuration logic, PLLs and SERDES Rx, Tx and PLL. All VCC12 pins must be connected. As VCC12 supplies power for analog circuitry, VCC12 should be quiet and isolated from noisy digital board supplies.
VTT_x	—	Termination voltage for bank x. When VTT termination is not required, or used to provide the common mode termination voltage (VCMT), these pins can be left unconnected on the device. VCMT function is not used in the bank. If the internal or external VCMT function for differential input termination is used, the VTT pins should be unconnected and allowed to float.
GND	—	GND - Ground. Dedicated pins. All grounds must be electrically connected at the board level.
VCC	—	VCC - The power supply pins for core logic. Dedicated pins (1.2V/1.0V).
VCCAUX	—	VCCAUX - Auxiliary power supply pin - powers all differential and referenced input buffers. Dedicated pins (2.5V).
VCCJ	—	VCCJ - The power supply pin for JTAG Test Access Port.
PROBE_VCC	—	VCC signal - Connected to internal VCC node. Can be used for feedback to control an external board power converter. Can be unconnected if not used.

© 2008 Lattice Semiconductor Corp. All Lattice trademarks, registered trademarks, patents, and disclaimers are as listed at [www.latticesemi.com/legal](http://www.latticesemi.com/legal). All other brand or product names are trademarks or registered trademarks of their respective holders. The specifications and information herein are subject to change without notice.

**LFSC/M15, LFSC/M25 Logic Signal Connections: 900 fpBGA<sup>1,2</sup>**

Ball Number	LFSC/M15			LFSC/M25		
	Ball Function	VCCIO Bank	Dual Function	Ball Function	VCCIO Bank	Dual Function
F7	A_VDDAX25_L	-		A_VDDAX25_L	-	
B1	A_REFCLKP_L	-		A_REFCLKP_L	-	
C1	A_REFCLKN_L	-		A_REFCLKN_L	-	
D5	VCC12	-		VCC12	-	
A2	RESP_ULC	-		RESP_ULC	-	
E5	VCC12	-		VCC12	-	
D4	VCC12	-		VCC12	-	
H5	RESETN	1		RESETN	1	
H6	TSALLN	1		TSALLN	1	
G6	DONE	1		DONE	1	
G5	INITN	1		INITN	1	
F5	M0	1		M0	1	
F6	M1	1		M1	1	
F4	M2	1		M2	1	
E4	M3	1		M3	1	
D3	PL15A	7	ULC_PLLT_IN_A/ULC_PLLT_FB_B	PL16A	7	ULC_PLLT_IN_A/ULC_PLLT_FB_B
D2	PL15B	7	ULC_PLLC_IN_A/ULC_PLLC_FB_B	PL16B	7	ULC_PLLC_IN_A/ULC_PLLC_FB_B
J6	PL15C	7		PL16C	7	
J5	PL15D	7		PL16D	7	
E3	PL17A	7	ULC_DLLT_IN_C/ULC_DLLT_FB_D	PL17A	7	ULC_DLLT_IN_C/ULC_DLLT_FB_D
E2	PL17B	7	ULC_DLLC_IN_C/ULC_DLLC_FB_D	PL17B	7	ULC_DLLC_IN_C/ULC_DLLC_FB_D
K4	PL17C	7	ULC_PLLT_IN_B/ULC_PLLT_FB_A	PL17C	7	ULC_PLLT_IN_B/ULC_PLLT_FB_A
J4	PL17D	7	ULC_PLLC_IN_B/ULC_PLLC_FB_A	PL17D	7	ULC_PLLC_IN_B/ULC_PLLC_FB_A
F3	PL18A	7	ULC_DLLT_IN_D/ULC_DLLT_FB_C	PL18A	7	ULC_DLLT_IN_D/ULC_DLLT_FB_C
G3	PL18B	7	ULC_DLLC_IN_D/ULC_DLLC_FB_C	PL18B	7	ULC_DLLC_IN_D/ULC_DLLC_FB_C
K5	PL18C	7		PL18C	7	
K6	PL18D	7	VREF2_7	PL18D	7	VREF2_7
F2	PL19A	7		PL22A	7	
F1	PL19B	7		PL22B	7	
E1	PL19C	7		PL22C	7	
D1	PL19D	7		PL22D	7	
K3	PL22A	7		PL25A	7	
L3	PL22B	7		PL25B	7	
L6	PL22C	7	VREF1_7	PL25C	7	VREF1_7
M6	PL22D	7	DIFFR_7	PL25D	7	DIFFR_7
J1	PL23A	7	PCLKT7_1	PL26A	7	PCLKT7_1
K1	PL23B	7	PCLKC7_1	PL26B	7	PCLKC7_1
L1	PL24A	7	PCLKT7_0	PL27A	7	PCLKT7_0
M1	PL24B	7	PCLKC7_0	PL27B	7	PCLKC7_0
P8	PL24C	7	PCLKT7_2	PL27C	7	PCLKT7_2
R8	PL24D	7	PCLKC7_2	PL27D	7	PCLKC7_2
N2	PL26A	6	PCLKT6_0	PL29A	6	PCLKT6_0
N1	PL26B	6	PCLKC6_0	PL29B	6	PCLKC6_0
R7	PL26C	6	PCLKT6_1	PL29C	6	PCLKT6_1
R6	PL26D	6	PCLKC6_1	PL29D	6	PCLKC6_1

**LFSC/M15, LFSC/M25 Logic Signal Connections: 900 fpBGA<sup>1,2</sup> (Cont.)**

Ball Number	LFSC/M15			LFSC/M25		
	Ball Function	VCCIO Bank	Dual Function	Ball Function	VCCIO Bank	Dual Function
Y9	VCCIO6	-		VCCIO6	-	
J7	VCCIO7	-		VCCIO7	-	
J8	VCCIO7	-		VCCIO7	-	
K7	VCCIO7	-		VCCIO7	-	
K8	VCCIO7	-		VCCIO7	-	
L8	VCCIO7	-		VCCIO7	-	
L9	VCCIO7	-		VCCIO7	-	
M9	VCCIO7	-		VCCIO7	-	
N9	VCCIO7	-		VCCIO7	-	
P9	VCCIO7	-		VCCIO7	-	
R9	VCCIO7	-		VCCIO7	-	
A1	GND	-		GND	-	
A30	GND	-		GND	-	
AA15	GND	-		GND	-	
AA16	GND	-		GND	-	
AK1	GND	-		GND	-	
AK30	GND	-		GND	-	
K15	GND	-		GND	-	
K16	GND	-		GND	-	
L11	GND	-		GND	-	
L12	GND	-		GND	-	
L13	GND	-		GND	-	
L14	GND	-		GND	-	
L15	GND	-		GND	-	
L16	GND	-		GND	-	
L17	GND	-		GND	-	
L18	GND	-		GND	-	
L19	GND	-		GND	-	
L20	GND	-		GND	-	
M11	GND	-		GND	-	
M12	GND	-		GND	-	
M13	GND	-		GND	-	
M14	GND	-		GND	-	
M15	GND	-		GND	-	
M16	GND	-		GND	-	
M17	GND	-		GND	-	
M18	GND	-		GND	-	
M19	GND	-		GND	-	
M20	GND	-		GND	-	
N11	GND	-		GND	-	
N12	GND	-		GND	-	
N13	GND	-		GND	-	
N14	GND	-		GND	-	
N15	GND	-		GND	-	
N16	GND	-		GND	-	



**LFSC/M25, LFSC/M40 Logic Signal Connections: 1020 fcBGA<sup>1,2</sup> (Cont.)**

Ball Number	LFSC/M25			LFSC/M40		
	Ball Function	VCCIO Bank	Dual Function	Ball Function	VCCIO Bank	Dual Function
P17	VCC	-		VCC	-	
P19	VCC	-		VCC	-	
R13	VCC	-		VCC	-	
R15	VCC	-		VCC	-	
R18	VCC	-		VCC	-	
R20	VCC	-		VCC	-	
T13	VCC	-		VCC	-	
T14	VCC	-		VCC	-	
T16	VCC	-		VCC	-	
T17	VCC	-		VCC	-	
T19	VCC	-		VCC	-	
T20	VCC	-		VCC	-	
U13	VCC	-		VCC	-	
U14	VCC	-		VCC	-	
U16	VCC	-		VCC	-	
U17	VCC	-		VCC	-	
U19	VCC	-		VCC	-	
U20	VCC	-		VCC	-	
V13	VCC	-		VCC	-	
V15	VCC	-		VCC	-	
V18	VCC	-		VCC	-	
V20	VCC	-		VCC	-	
W14	VCC	-		VCC	-	
W16	VCC	-		VCC	-	
W17	VCC	-		VCC	-	
W19	VCC	-		VCC	-	
Y13	VCC	-		VCC	-	
Y15	VCC	-		VCC	-	
Y16	VCC	-		VCC	-	
Y17	VCC	-		VCC	-	
Y18	VCC	-		VCC	-	
Y20	VCC	-		VCC	-	
C17	VCCIO1	-		VCCIO1	-	
D16	VCCIO1	-		VCCIO1	-	
F15	VCCIO1	-		VCCIO1	-	
F24	VCCIO1	-		VCCIO1	-	
G18	VCCIO1	-		VCCIO1	-	
G9	VCCIO1	-		VCCIO1	-	
J11	VCCIO1	-		VCCIO1	-	
J19	VCCIO1	-		VCCIO1	-	
K14	VCCIO1	-		VCCIO1	-	
K22	VCCIO1	-		VCCIO1	-	
G4	VCCIO2	-		VCCIO2	-	
J7	VCCIO2	-		VCCIO2	-	
K3	VCCIO2	-		VCCIO2	-	
L10	VCCIO2	-		VCCIO2	-	
M6	VCCIO2	-		VCCIO2	-	
N4	VCCIO2	-		VCCIO2	-	
P9	VCCIO2	-		VCCIO2	-	
R7	VCCIO2	-		VCCIO2	-	

**LFSC/M25, LFSC/M40 Logic Signal Connections: 1020 fcBGA<sup>1,2</sup> (Cont.)**

Ball Number	LFSC/M25			LFSC/M40		
	Ball Function	VCCIO Bank	Dual Function	Ball Function	VCCIO Bank	Dual Function
AA21	VCCAUX	-		VCCAUX	-	
AA22	VCCAUX	-		VCCAUX	-	
AB11	VCCAUX	-		VCCAUX	-	
AB12	VCCAUX	-		VCCAUX	-	
AB15	VCCAUX	-		VCCAUX	-	
AB16	VCCAUX	-		VCCAUX	-	
AB17	VCCAUX	-		VCCAUX	-	
AB18	VCCAUX	-		VCCAUX	-	
AB21	VCCAUX	-		VCCAUX	-	
AB22	VCCAUX	-		VCCAUX	-	
L11	VCCAUX	-		VCCAUX	-	
L12	VCCAUX	-		VCCAUX	-	
L14	VCCAUX	-		VCCAUX	-	
L15	VCCAUX	-		VCCAUX	-	
L18	VCCAUX	-		VCCAUX	-	
L19	VCCAUX	-		VCCAUX	-	
L21	VCCAUX	-		VCCAUX	-	
L22	VCCAUX	-		VCCAUX	-	
M11	VCCAUX	-		VCCAUX	-	
M12	VCCAUX	-		VCCAUX	-	
M21	VCCAUX	-		VCCAUX	-	
M22	VCCAUX	-		VCCAUX	-	
P11	VCCAUX	-		VCCAUX	-	
P22	VCCAUX	-		VCCAUX	-	
R11	VCCAUX	-		VCCAUX	-	
R22	VCCAUX	-		VCCAUX	-	
V11	VCCAUX	-		VCCAUX	-	
V22	VCCAUX	-		VCCAUX	-	
W11	VCCAUX	-		VCCAUX	-	
W22	VCCAUX	-		VCCAUX	-	
N11	VTT_2	2		VTT_2	2	
R10	VTT_2	2		VTT_2	2	
T11	VTT_3	3		VTT_3	3	
U11	VTT_3	3		VTT_3	3	
Y11	VTT_3	3		VTT_3	3	
AB13	VTT_4	4		VTT_4	4	
AB14	VTT_4	4		VTT_4	4	
AC15	VTT_4	4		VTT_4	4	
AB19	VTT_5	5		VTT_5	5	
AB20	VTT_5	5		VTT_5	5	
AC18	VTT_5	5		VTT_5	5	
T22	VTT_6	6		VTT_6	6	
U22	VTT_6	6		VTT_6	6	
Y22	VTT_6	6		VTT_6	6	
N22	VTT_7	7		VTT_7	7	
R23	VTT_7	7		VTT_7	7	
M17	VCC12	-		VCC12	-	
M16	VCC12	-		VCC12	-	
T12	VCC12	-		VCC12	-	
T21	VCC12	-		VCC12	-	

**LFSC/M40, LFSC/M80 Logic Signal Connections: 1152 fcBGA<sup>1,2</sup>**

Ball Number	LFSC/M40			LFSC/M80		
	Ball Function	VCCIO Bank	Dual Function	Ball Function	VCCIO Bank	Dual Function
G27	A_REFCLKP_L	-		A_REFCLKP_L	-	
H27	A_REFCLKN_L	-		A_REFCLKN_L	-	
H25	VCC12	-		VCC12	-	
H26	RESP_ULC	-		RESP_ULC	-	
B33	RESETN	1		RESETN	1	
C34	TSALLN	1		TSALLN	1	
D34	DONE	1		DONE	1	
C33	INITN	1		INITN	1	
J27	M0	1		M0	1	
K27	M1	1		M1	1	
M26	M2	1		M2	1	
L26	M3	1		M3	1	
F30	PL16A	7	ULC_PLLT_IN_A/ULC_PLLT_FB_B	PL16A	7	ULC_PLLT_IN_A/ULC_PLLT_FB_B
G30	PL16B	7	ULC_PLLC_IN_A/ULC_PLLC_FB_B	PL16B	7	ULC_PLLC_IN_A/ULC_PLLC_FB_B
H28	PL16C	7		PL16C	7	
J28	PL16D	7		PL16D	7	
F31	PL17A	7	ULC_DLLT_IN_C/ULC_DLLT_FB_D	PL17A	7	ULC_DLLT_IN_C/ULC_DLLT_FB_D
G31	PL17B	7	ULC_DLLC_IN_C/ULC_DLLC_FB_D	PL17B	7	ULC_DLLC_IN_C/ULC_DLLC_FB_D
N25	PL17C	7	ULC_PLLT_IN_B/ULC_PLLT_FB_A	PL17C	7	ULC_PLLT_IN_B/ULC_PLLT_FB_A
P25	PL17D	7	ULC_PLLC_IN_B/ULC_PLLC_FB_A	PL17D	7	ULC_PLLC_IN_B/ULC_PLLC_FB_A
D33	PL18A	7	ULC_DLLT_IN_D/ULC_DLLT_FB_C	PL18A	7	ULC_DLLT_IN_D/ULC_DLLT_FB_C
E33	PL18B	7	ULC_DLLC_IN_D/ULC_DLLC_FB_C	PL18B	7	ULC_DLLC_IN_D/ULC_DLLC_FB_C
H29	PL18C	7		PL18C	7	
J29	PL18D	7	VREF2_7	PL18D	7	VREF2_7
F32	PL21A	7		PL20A	7	
G32	PL21B	7		PL20B	7	
P26	PL21C	7		PL20C	7	
N26	PL21D	7		PL20D	7	
H30	PL22A	7		PL21A	7	
J30	PL22B	7		PL21B	7	
L28	PL22C	7		PL21C	7	
M28	PL22D	7		PL21D	7	
J31	PL23A	7		PL29A	7	
K31	PL23B	7		PL29B	7	
L27	PL23C	7	VREF1_7	PL29C	7	VREF1_7
M27	PL23D	7	DIFFR_7	PL29D	7	DIFFR_7
J32	PL25A	7		PL31A	7	
K32	PL25B	7		PL31B	7	
L29	PL25C	7		PL31C	7	
M29	PL25D	7		PL31D	7	
H33	PL26A	7		PL33A	7	
J33	PL26B	7		PL33B	7	
N27	PL26C	7		PL33C	7	
P27	PL26D	7		PL33D	7	
K33	PL27A	7		PL35A	7	

**LFSC/M40, LFSC/M80 Logic Signal Connections: 1152 fcBGA<sup>1,2</sup> (Cont.)**

Ball Number	LFSC/M40			LFSC/M80		
	Ball Function	VCCIO Bank	Dual Function	Ball Function	VCCIO Bank	Dual Function
AH11	PB57D	4		PB79D	4	
AN13	PB58A	4	PCLKT4_3	PB80A	4	PCLKT4_3
AN12	PB58B	4	PCLKC4_3	PB80B	4	PCLKC4_3
AD14	PB58C	4	PCLKT4_4	PB80C	4	PCLKT4_4
AD15	PB58D	4	PCLKC4_4	PB80D	4	PCLKC4_4
AP13	PB61A	4		PB73A	4	
AP12	PB61B	4		PB73B	4	
AK13	PB61C	4		PB73C	4	
AK12	PB61D	4		PB73D	4	
AP11	PB62A	4		PB83A	4	
AP10	PB62B	4		PB83B	4	
AN11	PB63A	4		PB99A	4	
AN10	PB63B	4		PB99B	4	
AF14	PB63C	4		PB99C	4	
AF13	PB63D	4		PB99D	4	
AM10	PB67A	4		PB101A	4	
AM9	PB67B	4		PB101B	4	
AE14	PB67C	4		PB101C	4	
AE13	PB67D	4		PB101D	4	
AP9	PB69A	4		PB104A	4	
AP8	PB69B	4		PB104B	4	
AK11	PB69C	4		PB104C	4	
AK10	PB69D	4		PB104D	4	
AL10	PB70A	4		PB107A	4	
AL9	PB70B	4		PB107B	4	
AF12	PB70C	4		PB107C	4	
AF11	PB70D	4		PB107D	4	
AN9	PB73A	4		PB109A	4	
AN8	PB73B	4		PB109B	4	
AG11	PB73C	4		PB109C	4	
AG10	PB73D	4		PB109D	4	
AP7	PB74A	4		PB111A	4	
AP6	PB74B	4		PB111B	4	
AG13	PB74C	4		PB111C	4	
AG12	PB74D	4		PB111D	4	
AN7	PB75A	4		PB113A	4	
AN6	PB75B	4		PB113B	4	
AK9	PB75C	4		PB113C	4	
AK8	PB75D	4		PB113D	4	
AP5	PB77A	4		PB115A	4	
AP4	PB77B	4		PB115B	4	
AD11	PB77C	4		PB115C	4	
AE11	PB77D	4		PB115D	4	
AM7	PB78A	4		PB117A	4	
AM6	PB78B	4		PB117B	4	

**LFSC/M115 Logic Signal Connections: 1152 fcBGA<sup>1, 2</sup>**

Ball Number	LFSC/M115		
	Ball Function	VCCIO Bank	Dual Function
H34	PL40B	7	
M32	PL53A	7	
N32	PL53B	7	
P28	PL53C	7	
R28	PL53D	7	
J34	PL55A	7	
K34	PL55B	7	
P30	PL55C	7	
R30	PL55D	7	
W34	PL73A	6	
Y34	PL73B	6	
W32	PL75A	6	
Y32	PL75B	6	
AA34	PL78A	6	
AB34	PL78B	6	
AC34	PL81A	6	
AD34	PL81B	6	
Y30	PL82A	6	
AA30	PL82B	6	
AB33	PL83A	6	
AC33	PL83B	6	
AC2	PR83B	3	
AB2	PR83A	3	
AA5	PR82B	3	
Y5	PR82A	3	
AD1	PR81B	3	
AC1	PR81A	3	
AB1	PR78B	3	
AA1	PR78A	3	
Y3	PR75B	3	
W3	PR75A	3	
Y1	PR73B	3	
W1	PR73A	3	
R5	PR55D	2	
P5	PR55C	2	
K1	PR55B	2	
J1	PR55A	2	
R7	PR53D	2	
P7	PR53C	2	
N3	PR53B	2	
M3	PR53A	2	
H1	PR40B	2	
G1	PR40A	2	

**LFSC/M115 Logic Signal Connections: 1152 fcBGA<sup>1, 2</sup>**

Ball Number	LFSC/M115		
	Ball Function	VCCIO Bank	Dual Function
K26	GND	-	
K28	GND	-	
K6	GND	-	
K9	GND	-	
L12	GND	-	
L32	GND	-	
L4	GND	-	
M10	GND	-	
M17	GND	-	
M24	GND	-	
N29	GND	-	
N7	GND	-	
P15	GND	-	
P20	GND	-	
P3	GND	-	
P31	GND	-	
R10	GND	-	
R14	GND	-	
R16	GND	-	
R19	GND	-	
R21	GND	-	
R26	GND	-	
T15	GND	-	
T17	GND	-	
T18	GND	-	
T20	GND	-	
T28	GND	-	
T6	GND	-	
U16	GND	-	
U19	GND	-	
U23	GND	-	
U32	GND	-	
U4	GND	-	
V12	GND	-	
V16	GND	-	
V19	GND	-	
V3	GND	-	
V31	GND	-	
W15	GND	-	
W17	GND	-	
W18	GND	-	
W20	GND	-	
W29	GND	-	

**LFSC/M80, LFSC/M115 Logic Signal Connections: 1704 fcBGA<sup>1,2</sup> (Cont.)**

Ball Number	LFSC/M80			LFSC/M115		
	Ball Function	VCCIO Bank	Dual Function	Ball Function	VCCIO Bank	Dual Function
AV32	PB27B	5		PB29B	5	
AU36	PB27C	5		PB29C	5	
AU37	PB27D	5		PB29D	5	
BA35	PB28A	5		PB30A	5	
BA34	PB28B	5		PB30B	5	
AJ26	PB28C	5		PB30C	5	
AJ27	PB28D	5		PB30D	5	
AW33	PB29A	5		PB31A	5	
AW32	PB29B	5		PB31B	5	
AU35	PB29C	5		PB31C	5	
AU34	PB29D	5		PB31D	5	
BB35	PB31A	5		PB33A	5	
BB34	PB31B	5		PB33B	5	
AN29	PB31C	5		PB33C	5	
AP29	PB31D	5		PB33D	5	
AY33	PB32A	5		PB34A	5	
AY32	PB32B	5		PB34B	5	
AR31	PB32C	5		PB34C	5	
AR30	PB32D	5		PB34D	5	
AV31	PB33A	5		PB35A	5	
AV30	PB33B	5		PB35B	5	
AN28	PB33C	5		PB35C	5	
AP28	PB33D	5		PB35D	5	
BA33	PB35A	5		PB37A	5	
BA32	PB35B	5		PB37B	5	
AT30	PB35C	5		PB37C	5	
AT31	PB35D	5		PB37D	5	
BB33	PB36A	5		PB38A	5	
BB32	PB36B	5		PB38B	5	
AM26	PB36C	5		PB38C	5	
AL26	PB36D	5		PB38D	5	
AW30	PB37A	5		PB39A	5	
AW29	PB37B	5		PB39B	5	
AP27	PB37C	5		PB39C	5	
AN27	PB37D	5		PB39D	5	
BA31	PB39A	5		PB41A	5	
BA30	PB39B	5		PB41B	5	
AU32	PB39C	5		PB41C	5	
AU33	PB39D	5		PB41D	5	
BB31	PB40A	5		PB42A	5	
BB30	PB40B	5		PB42B	5	
AR28	PB40C	5		PB42C	5	
AR27	PB40D	5		PB42D	5	
AV29	PB41A	5		PB43A	5	
AV28	PB41B	5		PB43B	5	

**LFSC/M80, LFSC/M115 Logic Signal Connections: 1704 fcBGA<sup>1,2</sup> (Cont.)**

Ball Number	LFSC/M80			LFSC/M115		
	Ball Function	VCCIO Bank	Dual Function	Ball Function	VCCIO Bank	Dual Function
AP1	PR90B	3		PR109B	3	
AN1	PR90A	3		PR109A	3	
AK10	PR89D	3	VREF2_3	PR107D	3	VREF2_3
AJ10	PR89C	3		PR107C	3	
AM5	PR89B	3		PR107B	3	
AL5	PR89A	3		PR107A	3	
AL7	PR86D	3		PR104D	3	
AK7	PR86C	3		PR104C	3	
AM1	PR86B	3		PR104B	3	
AL1	PR86A	3		PR104A	3	
AJ11	PR85D	3		PR103D	3	
AH11	PR85C	3		PR103C	3	
AK5	PR85B	3		PR103B	3	
AJ5	PR85A	3		PR103A	3	
AK9	PR84D	3		PR99D	3	
AJ9	PR84C	3		PR99C	3	
AK3	PR84B	3		PR99B	3	
AJ3	PR84A	3		PR99A	3	
AK6	PR82D	3		PR98D	3	
AJ6	PR82C	3		PR98C	3	
AK2	PR82B	3		PR98B	3	
AJ2	PR82A	3		PR98A	3	
AH10	PR81D	3		PR96D	3	
AG10	PR81C	3		PR96C	3	
AK1	PR81B	3		PR96B	3	
AJ1	PR81A	3		PR96A	3	
AH9	PR80D	3		PR94D	3	
AG9	PR80C	3		PR94C	3	
AH2	PR80B	3		PR94B	3	
AG2	PR80A	3		PR94A	3	
AH8	PR78D	3		PR92D	3	
AG8	PR78C	3		PR92C	3	
AG1	PR78B	3		PR92B	3	
AH1	PR78A	3		PR92A	3	
AG14	PR77D	3		PR91D	3	
AF14	PR77C	3		PR91C	3	
AG4	PR77B	3		PR91B	3	
AF4	PR77A	3		PR91A	3	
AH7	PR76D	3	DIFFR_3	PR90D	3	DIFFR_3
AG7	PR76C	3		PR90C	3	
AG3	PR76B	3		PR90B	3	
AF3	PR76A	3		PR90A	3	
AH6	PR74D	3		PR88D	3	
AG6	PR74C	3		PR88C	3	
AF1	PR74B	3		PR88B	3	



**LFSC/M80, LFSC/M115 Logic Signal Connections: 1704 fcBGA<sup>1,2</sup> (Cont.)**

Ball Number	LFSC/M80			LFSC/M115		
	Ball Function	VCCIO Bank	Dual Function	Ball Function	VCCIO Bank	Dual Function
AC24	GND	-		GND	-	
AC26	GND	-		GND	-	
AC35	GND	-		GND	-	
AC8	GND	-		GND	-	
AD12	GND	-		GND	-	
AD16	GND	-		GND	-	
AD18	GND	-		GND	-	
AD20	GND	-		GND	-	
AD23	GND	-		GND	-	
AD25	GND	-		GND	-	
AD27	GND	-		GND	-	
AD31	GND	-		GND	-	
AE17	GND	-		GND	-	
AE19	GND	-		GND	-	
AE24	GND	-		GND	-	
AE26	GND	-		GND	-	
AE3	GND	-		GND	-	
AE39	GND	-		GND	-	
AF18	GND	-		GND	-	
AF20	GND	-		GND	-	
AF23	GND	-		GND	-	
AF25	GND	-		GND	-	
AF36	GND	-		GND	-	
AF7	GND	-		GND	-	
AG11	GND	-		GND	-	
AG16	GND	-		GND	-	
AG19	GND	-		GND	-	
AG24	GND	-		GND	-	
AG27	GND	-		GND	-	
AG32	GND	-		GND	-	
AH15	GND	-		GND	-	
AH28	GND	-		GND	-	
AH4	GND	-		GND	-	
AH40	GND	-		GND	-	
AJ35	GND	-		GND	-	
AJ8	GND	-		GND	-	
AK12	GND	-		GND	-	
AK31	GND	-		GND	-	
AL13	GND	-		GND	-	
AL19	GND	-		GND	-	
AL24	GND	-		GND	-	
AL3	GND	-		GND	-	
AL30	GND	-		GND	-	
AL39	GND	-		GND	-	
AM16	GND	-		GND	-	

**LFSC/M80, LFSC/M115 Logic Signal Connections: 1704 fcBGA<sup>1,2</sup> (Cont.)**

Ball Number	LFSC/M80			LFSC/M115		
	Ball Function	VCCIO Bank	Dual Function	Ball Function	VCCIO Bank	Dual Function
AH22	VTT_5	5		VTT_5	5	
AJ22	VTT_5	5		VTT_5	5	
AJ23	VTT_5	5		VTT_5	5	
AJ24	VTT_5	5		VTT_5	5	
AJ25	VTT_5	5		VTT_5	5	
AB28	VTT_6	6		VTT_6	6	
AB29	VTT_6	6		VTT_6	6	
AE29	VTT_6	6		VTT_6	6	
AJ30	VTT_6	6		VTT_6	6	
AA28	VTT_7	7		VTT_7	7	
AA29	VTT_7	7		VTT_7	7	
R31	VTT_7	7		VTT_7	7	
V29	VTT_7	7		VTT_7	7	
Y24	GND	-		GND	-	
Y26	GND	-		GND	-	
Y8	GND	-		GND	-	
Y35	GND	-		GND	-	
AA16	VCC12	-		VCC12	-	
AA27	VCC12	-		VCC12	-	
AB16	VCC12	-		VCC12	-	
AB27	VCC12	-		VCC12	-	
AF16	VCC12	-		VCC12	-	
AF27	VCC12	-		VCC12	-	
AG17	VCC12	-		VCC12	-	
AG21	VCC12	-		VCC12	-	
G33	NC	-		NC	-	
G10	NC	-		NC	-	
M15	NC	-		NC	-	
L15	NC	-		NC	-	
K16	NC	-		NC	-	
J16	NC	-		NC	-	
M18	NC	-		NC	-	
L18	NC	-		NC	-	
M25	NC	-		NC	-	
L25	NC	-		NC	-	
J27	NC	-		NC	-	
K27	NC	-		NC	-	
L28	NC	-		NC	-	
M28	NC	-		NC	-	

1. Differential pair grouping within a PIC is A (True) and B (Complement) and C (True) and D (Complement).
2. The LatticeSC/M80 and LatticeSC/M115 in a 1704-pin package supports a 32-bit MPI interface.

## Commercial, Cont.

Part Number	Grade	Package	Balls	Temp.	LUTs (K)
LFSC3GA80E-7FCN1152C <sup>1</sup>	-7	Lead-Free Ceramic fcBGA	1152	COM	80.1
LFSC3GA80E-6FCN1152C <sup>1</sup>	-6	Lead-Free Ceramic fcBGA	1152	COM	80.1
LFSC3GA80E-5FCN1152C <sup>1</sup>	-5	Lead-Free Ceramic fcBGA	1152	COM	80.1
LFSC3GA80E-7FFN1152C	-7	Lead-Free Organic fcBGA	1152	COM	80.1
LFSC3GA80E-6FFN1152C	-6	Lead-Free Organic fcBGA	1152	COM	80.1
LFSC3GA80E-5FFN1152C	-5	Lead-Free Organic fcBGA	1152	COM	80.1
LFSC3GA80E-7FCN1704C <sup>1</sup>	-7	Lead-Free Ceramic fcBGA	1704	COM	80.1
LFSC3GA80E-6FCN1704C <sup>1</sup>	-6	Lead-Free Ceramic fcBGA	1704	COM	80.1
LFSC3GA80E-5FCN1704C <sup>1</sup>	-5	Lead-Free Ceramic fcBGA	1704	COM	80.1
LFSC3GA80E-7FFN1704C	-7	Lead-Free Organic fcBGA	1704	COM	80.1
LFSC3GA80E-6FFN1704C	-6	Lead-Free Organic fcBGA	1704	COM	80.1
LFSC3GA80E-5FFN1704C	-5	Lead-Free Organic fcBGA	1704	COM	80.1

1. Converted to organic flip-chip BGA package per [PCN #01A-10](#).

Part Number	Grade	Package	Balls	Temp.	LUTs (K)
LFSCM3GA80EP1-7FCN1152C <sup>1</sup>	-7	Lead-Free Ceramic fcBGA	1152	COM	80.1
LFSCM3GA80EP1-6FCN1152C <sup>1</sup>	-6	Lead-Free Ceramic fcBGA	1152	COM	80.1
LFSCM3GA80EP1-5FCN1152C <sup>1</sup>	-5	Lead-Free Ceramic fcBGA	1152	COM	80.1
LFSCM3GA80EP1-7FFN1152C	-7	Lead-Free Organic fcBGA	1152	COM	80.1
LFSCM3GA80EP1-6FFN1152C	-6	Lead-Free Organic fcBGA	1152	COM	80.1
LFSCM3GA80EP1-5FFN1152C	-5	Lead-Free Organic fcBGA	1152	COM	80.1
LFSCM3GA80EP1-7FCN1704C <sup>1</sup>	-7	Lead-Free Ceramic fcBGA	1704	COM	80.1
LFSCM3GA80EP1-6FCN1704C <sup>1</sup>	-6	Lead-Free Ceramic fcBGA	1704	COM	80.1
LFSCM3GA80EP1-5FCN1704C <sup>1</sup>	-5	Lead-Free Ceramic fcBGA	1704	COM	80.1
LFSCM3GA80EP1-7FFN1704C	-7	Lead-Free Organic fcBGA	1704	COM	80.1
LFSCM3GA80EP1-6FFN1704C	-6	Lead-Free Organic fcBGA	1704	COM	80.1
LFSCM3GA80EP1-5FFN1704C	-5	Lead-Free Organic fcBGA	1704	COM	80.1

1. Converted to organic flip-chip BGA package per [PCN #01A-10](#).

Part Number	Grade	Package	Balls	Temp.	LUTs (K)
LFSC3GA115E-6FCN1152C <sup>1</sup>	-6	Lead-Free Ceramic fcBGA	1152	COM	115.2
LFSC3GA115E-5FCN1152C <sup>1</sup>	-5	Lead-Free Ceramic fcBGA	1152	COM	115.2
LFSC3GA115E-6FFN1152C	-6	Lead-Free Organic fcBGA	1152	COM	115.2
LFSC3GA115E-5FFN1152C	-5	Lead-Free Organic fcBGA	1152	COM	115.2
LFSC3GA115E-6FCN1704C <sup>1</sup>	-6	Lead-Free Ceramic fcBGA	1704	COM	115.2
LFSC3GA115E-5FCN1704C <sup>1</sup>	-5	Lead-Free Ceramic fcBGA	1704	COM	115.2
LFSC3GA115E-6FFN1704C	-6	Lead-Free Organic fcBGA	1704	COM	115.2
LFSC3GA115E-5FFN1704C	-5	Lead-Free Organic fcBGA	1704	COM	115.2

1. Converted to organic flip-chip BGA package per [PCN #01A-10](#).

## For Further Information

For further information about the flexiPCS, see the [LatticeSC/M Family flexiPCS Data Sheet](#).

A variety of technical notes for the LatticeSC/M family are also available on the Lattice Semiconductor website at [www.latticesemi.com](http://www.latticesemi.com).

- [LatticeSC PURESPEED I/O Usage Guide](#) (TN1088)
- [LatticeSC PURESPEED I/O Adaptive Input Logic User's Guide](#) (TN1158)
- [LatticeSC sysCLOCK PLL/DLL User's Guide](#) (TN1098)
- [On-Chip Memory Usage Guide for LatticeSC Devices](#) (TN1094)
- [LatticeSC/M DDR/DDR2 SDRAM Memory Interface User's Guide](#) (TN1099)
- [LatticeSC QDRII/II+ SRAM Memory Interface User's Guide](#) (TN1096)
- [LatticeSC sysCONFIG Usage Guide](#) (TN1080)
- [LatticeSC MPI/System Bus](#) (TN1085)
- [SPI Serial Flash Programming Using ispJTAG in LatticeSC Devices](#) (TN1100)
- [Power Estimation and Management for LatticeSC Devices](#) (TN1101)
- [LatticeSC SERDES Jitter](#) (TN1084)
- [LatticeSC FPGAs: Implementing 3.3V Interfaces in 2.5V VCCIO Banks](#) (TN1110)
- [Lattice PCI Express Basic Demo User's Guide](#) (UG08)
- [LatticeSC flexiPCS/SERDES Design Guide](#) (TN1145)
- [Temperature Sensing Diode in LatticeSC Devices](#) (TN1115)
- [SPI4.2 Interoperability Between ORSPI4 and LatticeSC Devices](#) (TN1116)

For further information on Interface standards refer to the following websites:

- JEDEC Standards (LVTTTL, LVCMOS, SSTL, HSTL): [www.jedec.org](http://www.jedec.org)
- Optical Interface (SPI-4.2, XSBI, CSIX and XGMII): [www.oiforum.com](http://www.oiforum.com)
- RAPIDIO: [www.rapidio.org](http://www.rapidio.org)
- PCI/PCIX: [www.pcisig.com](http://www.pcisig.com)

Date	Version	Section	Change Summary
August 2006 (cont.)	01.3 (cont.)	DC and Switching Characteristics (cont.)	Updated LatticeSC Family Timing Adders with ispLEVER 6.0 SP1 results
			Updated PLL Timing Parameters based on PDE testing results
			Removed RDDATA parameter from sysCONFIG readback timing table
		Multiple	Changed TDO/RDDATA to TDO
		Pinout Information	Removed all MPI signals from SC15 256 pin package Dual Function Column
			Added note to SC15, SC25 900 pin package that the package supports a 16 bit MPI
			Added note that pin D3 in an SC15 and SC25 900 pin package should not be used for single-ended outputs
			Added note that pin D28 in an SC15 and SC25 900 pin package should not be used for single-ended outputs
			Added note to SC25 1020 pin package that the package supports a 16 bit MPI
			Added note to SC80 1152 pin package that the package supports a 32 bit MPI
Added note to SC80 1704 pin package that the package supports a 32 bit MPI			
Ordering Information	Changed "fcBGA" for the 1020 packages to "ffBGA"		
November 2006	01.4	Introduction	LatticeSC Family Selection Guide table – I/O count for SC80 device, 1704 fcBGA package changed to 904/32. I/O count for SC115 device, 1704 fcBGA package changed to 942/32.
		DC and Switching Characteristics	DC Electrical Characteristics table – Updated the initialization and standby supply current values.
			DC Electrical Characteristics table – Updated the sysCONFIG Master Parallel mode RCLK low and RCLK high time specifications.
			DC Electrical Characteristics table – Updated VCCIO values for LVPECL33 I/Os.
		Pin Information	Pin Information Summary table - Changed number of single ended user I/Os from 906 to 904 for 1704 fcBGA.
			Removed the single-ended only output restriction on pins D3 and D28 in an SC15 and SC25 900 pin package.
		Ordering Information	Ordering Information tables - Changed number of I/Os from 906 to 904 for 1704 fcBGA.
			Added ordering part numbers for LatticeSC/SCM 40K and 115K LUT devices.
			Added lead-free ordering part numbers.
		Multiple	Changed number of available SC80 I/O from 906 to 904.
Changed number of available SC115 I/O from 944 to 942.			
January 2007	01.4a	Architecture	Added EBR Asynchronous Reset section.
February 2007	01.4b	Architecture	Updated EBR Asynchronous Reset section.
March 2007	01.5	Architecture	Added EBR asynchronous reset clarification
			Clarified that differential drivers are not supported in banks 1, 4 and 5
		DC and Switching Characteristics	Added clarification for the description of the junction temperature specification in the Absolute Maximum Ratings section.
			Updated Initialization and Standby Current table.
Updated LatticeSC External Switching Characteristics with ispLEVER 6.1 SP1 results.			